

400Gb/s QSFP-DD SR4 BiDi Optical Transceiver Module

Product Specification

Features

- **QSFP-DD MSA compliant**
- **8x53.125Gb/s electrical interface (400GAUI-8)**
- **Up to 150m OM5 MMF transmission**
- **Operating case temperature: 0 to 70°C**
- **Single 3.3V power supply**
- **Maximum power consumption 12W**
- **MPO-12 optical connector**
- **RoHS-6 compliant**



Applications

- **Data Center**
- **Infiniband HDR, EDR**



1. General Description

This product can support 400Gb/s bit rates. It is a parallel Quad Small Form-factor Pluggable—double density (QSFP-DD) Bi-Direction optical module. The module accepts eight host electrical data and transmits them in two groups of optical bi-directional lanes (each group contains 4 pairs of optical lane) to allow optical communication over optical multi-mode fibers. Reversely, on the receiver side, the module accepts 8 sets of optical input signal and converts them to 8 channels of electrical data.

An optical fiber with an MPO-12 connector can be plugged into the QSFP-DD module receptacle. Proper alignment is ensured by the guide pins inside the receptacle. The cable usually cannot be twisted for proper channel to channel alignment. Electrical connection is achieved through an MSA-compliant 76-pin edge type connector.

The module operates by a single +3.3V power supply. LVCMOS/LVTTL global control signals, such as Module Present, Reset, Interrupt and Low Power Mode, are available with the modules. A 2-wire serial interface is available to send and receive more complex control signals, and to receive digital diagnostic information. Individual channels can be addressed and unused channels can be shut down for maximum design flexibility.

The product is designed with form factor, optical/electrical connection and digital diagnostic interface according to the QSFP28 Multi-Source Agreement (MSA). It has been designed to meet the harshest external operating conditions including temperature, humidity and EMI interference. The module offers very high functionality and feature integration, accessible via a two-wire serial interface.

2. Functional Description

This product can support 425Gb/s bit rates. It is a parallel Quad Small Form-factor Pluggable—double density (QSFP-DD) Bi-Direction optical module. The module converts eight host electrical data into two groups of optical bi-directional lanes (each group contains 4 pairs of optical lane) to allow optical communication over optical multi-mode fibers. The transmitter of first group is 850nm VCSEL basis, it is 908nm VCSEL basis for the second group. On the receiver side, the module accepts 8 sets of optical input signal and transmits them to 8 channels of electrical data. The receiver module outputs electrical signals are also voltage compatible with Common Mode Logic (CML) levels.

This product is allowed for two typical applications: The first application is QSFP-DD SR4.2 to QSFP-DD SR4.2 point to point communication. The second application is QSFP-DD SR4.2 to 4x QSFP28 SR1.2 breakout communication. Figure 1 shows the functional block diagram of this product.

A single +3.3V power supply is required to power up this product. All the power supply pins are internally connected and should be applied concurrently. As per MSA specifications the module offers seven low speed hardware control pins (including the 2-wire serial interface): ModSelL, SCL, SDA, ResetL, InitMode, ModPrsL and IntL.

Module Select (ModSelL) is an input pin. When held low by the host, this product responds to 2-wire



serial communication commands. The ModSelL allows the use of this product on a single 2-wire interface bus – individual ModSelL lines must be used.

Serial Clock (SCL) and Serial Data (SDA) are required for the 2-wire serial bus communication interface and enable the host to access the memory map.

The ResetL pin enables a complete reset, returning the settings to their default state, when a low level on the ResetL pin is held for longer than the minimum pulse length. During the execution of a reset the host shall disregard all status bits until it indicates a completion of the reset interrupt. The product indicates this by posting an IntL (Interrupt) signal with the Data_Not_Ready bit negated in the memory map. Note that on power up (including hot insertion) the module should post this completion of reset interrupt without requiring a reset.

Initialize Mode (InitMode) is an input signal. It is pulled up to Vcc in the QSFP-DD module. The InitMode signal allows the host to define whether the QSFP-DD module will initialize under host software control (InitMode asserted High) or module hardware control (InitMode deasserted Low). Under host software control, the module shall remain in Low Power Mode until software enables the transition to High Power Mode, as defined in the QSFP-DD Management Interface Specification. Under hardware control (InitMode de-asserted Low), the module may immediately transition to High Power Mode after the management interface is initialized. The host shall not change the state of this signal while the module is present. In legacy QSFP applications, this signal is named LPMMode. See SFF-8679 for LPMMode signal description.

Module Present (ModPrsL) is a signal local to the host board which, in the absence of a product, is normally pulled up to the host Vcc. When the product is inserted into the connector, it completes the path to ground through a resistor on the host board and asserts the signal. ModPrsL then indicates its present by setting ModPrsL to a “Low” state.

Interrupt (IntL) is an output pin. “Low” indicates a possible operational fault or a status critical to the host system. The host identifies the source of the interrupt using the 2-wire serial interface. The IntL pin is an open collector output and must be pulled to the Host Vcc voltage on the Host board.

3. Transceiver Block Diagram

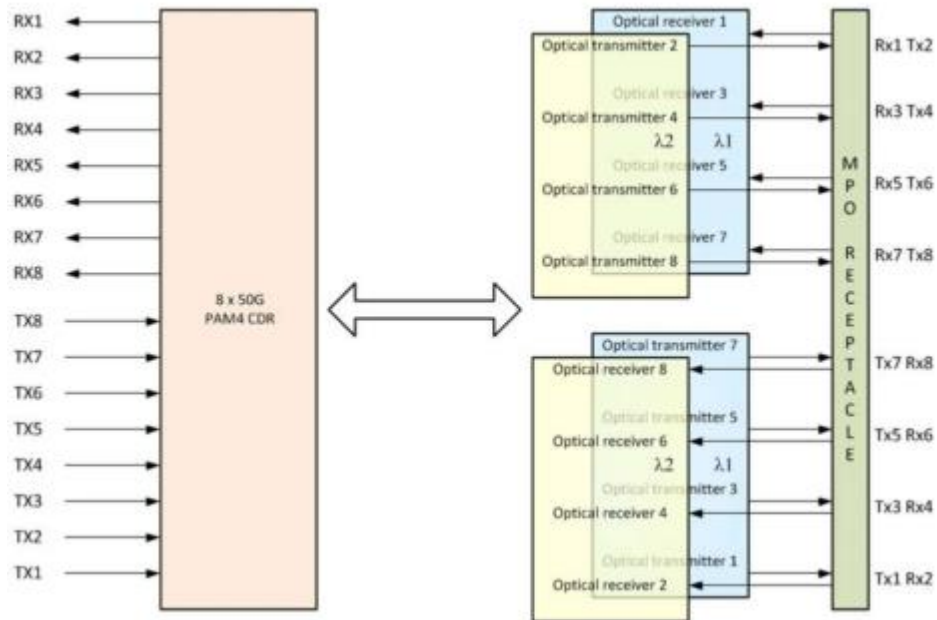

Figure 1. Transceiver Block Diagram

4. Pin Assignment and Description

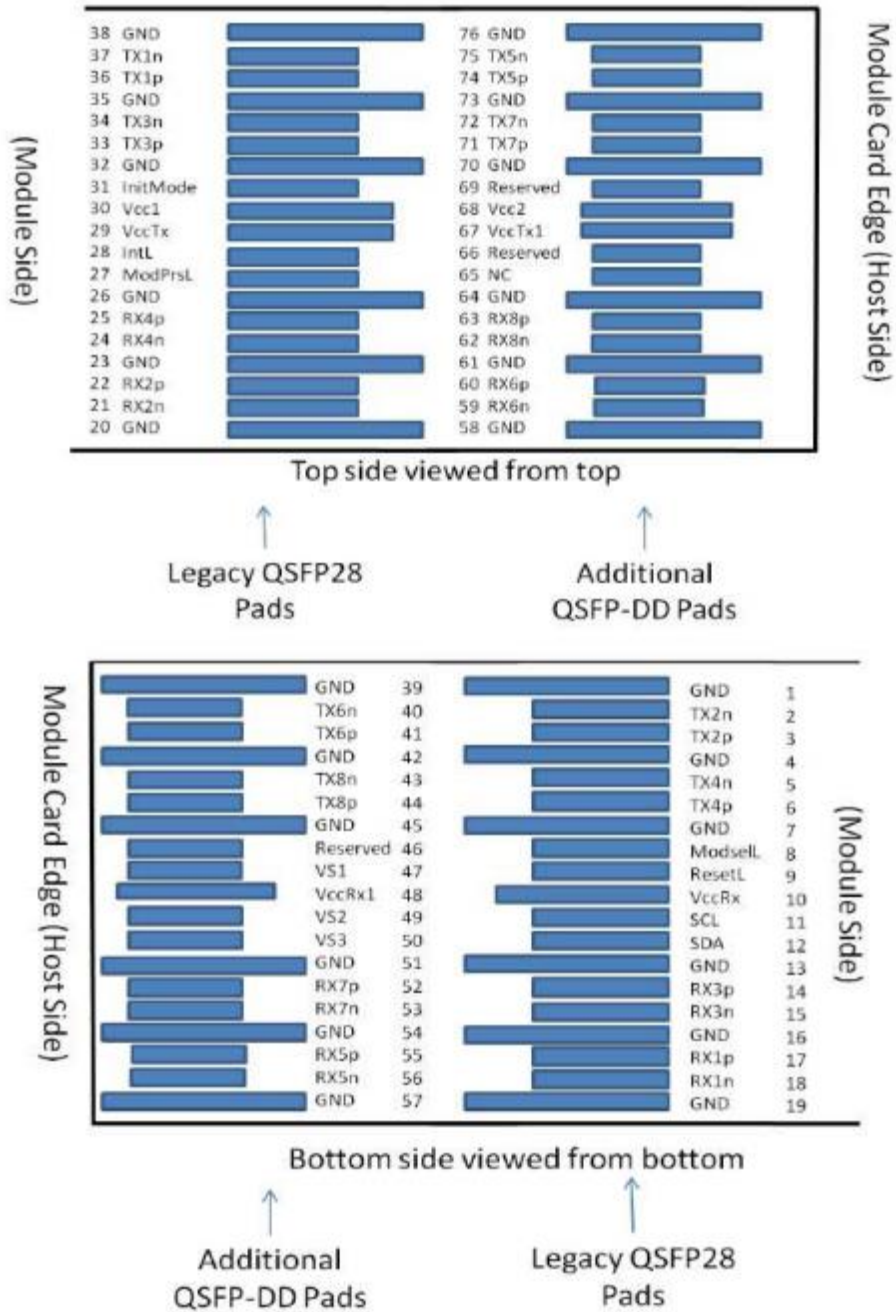

Figure 2. MSA Compliant Connector

Pin Definition

Pin #	Logic	Symbol		
1		GND	Ground	1B
2	CML-I	Tx2n	Transmitter Inverted Data Input	3B
3	CML-I	Tx2p	Transmitter Non-Inverted Data Input	3B
4		GND	Ground	1B
5	CML-I	Tx4n	Transmitter Inverted Data Input	3B
6	CML-I	Tx4p	Transmitter Non-Inverted Data Input	3B
7		GND	Ground	1B
8	LVTTL-I	ModSelL	Module Select	3B
9	LVTTL-I	ResetL	Module Reset	3B
10		VccRx	+3.3V Power Supply Receiver	2B
11	LVC MOS-I/O	SCL	2-wire serial interface clock	3B
12	LVC MOS-I/O	SDA	2-wire serial interface data	3B
13		GND	Ground	1B
14	CML-O	Rx3p	Receiver Non-Inverted Data Output	3B
15	CML-O	Rx3n	Receiver Inverted Data Output	3B
16		GND	Ground	1B
17	CML-O	Rx1p	Receiver Non-Inverted Data Output	3B
18	CML-O	Rx1n	Receiver Inverted Data Output	3B
19		GND	Ground	1B
20		GND	Ground	1B
21	CML-O	Rx2n	Receiver Inverted Data Output	3B
22	CML-O	Rx2p	Receiver Non-Inverted Data Output	3B
23		GND	Ground	1B
24	CML-O	Rx4n	Receiver Inverted Data Output	3B
25	CML-O	Rx4p	Receiver Non-Inverted Data Output	3B
26		GND	Ground	1B
27	LVTTL-O	ModPrsL	Module Present	3B
28	LVTTL-O	IntL	Interrupt	3B
29		VccTx	+3.3V Power supply transmitter	2B
30		Vcc1	+3.3V Power supply	2B
31	LVTTL-I	InitMode	Initialization mode; In legacy QSFP applications, the InitMode pad is called LPMODE	3B
32		GND	Ground	1B
33	CML-I	Tx3p	Transmitter Non-Inverted Data Input	3B
34	CML-I	Tx3n	Transmitter Inverted Data Input	3B
35		GND	Ground	1B
36	CML-I	Tx1p	Transmitter Non-Inverted Data Input	3B
37	CML-I	Tx1n	Transmitter Inverted Data Input	3B
38		GND	Ground	1B

39		GND	Ground	1A
40	CML-I	Tx6n	Transmitter Inverted Data Input	3A
41	CML-I	Tx6p	Transmitter Non-Inverted Data Input	3A
42		GND	Ground	1A
43	CML-I	Tx8n	Transmitter Inverted Data Input	3A
44	CML-I	Tx8p	Transmitter Non-Inverted Data Input	3A
45		GND	Ground	1A
46		Reserved	For future use	3A
47		VS1	Module Vendor Specific 1	3A
48		VccRx1	3.3V Power Supply	2A
49		VS2	Module Vendor Specific 2	3A
50		VS3	Module Vendor Specific 3	3A
51		GND	Ground	1A
52	CML-O	Rx7p	Receiver Non-Inverted Data Output	3A
53	CML-O	Rx7n	Receiver Inverted Data Output	3A
54		GND	Ground	1A
55	CML-O	Rx5p	Receiver Non-Inverted Data Output	3A
56	CML-O	Rx5n	Receiver Inverted Data Output	3A
57		GND	Ground	1A
58		GND	Ground	1A
59	CML-O	Rx6n	Receiver Inverted Data Output	3A
60	CML-O	Rx6p	Receiver Non-Inverted Data Output	3A
61		GND	Ground	1A
62	CML-O	Rx8n	Receiver Inverted Data Output	3A
63	CML-O	Rx8p	Receiver Non-Inverted Data Output	3A
64		GND	Ground	1A
65		NC	No Connect	3A
66		Reserved	For future use	3A
67		VccTx1	3.3V Power Supply	2A
68		Vcc2	3.3V Power Supply	2A
69		Reserved	For Future Use	3A
70		GND	Ground	1A
71	CML-I	Tx7p	Transmitter Non-Inverted Data Input	3A
72	CML-I	Tx7n	Transmitter Inverted Data Input	3A
73		GND	Ground	1A
74	CML-I	Tx5p	Transmitter Non-Inverted Data Input	3A
75	CML-I	Tx5n	Transmitter Inverted Data Input	3A
76		GND	Ground	1A

5. Optical Interface Lanes and Assignment

Figure 3 shows the orientation of the multi-mode fiber facets of the optical connector. Table 1 provides the lane assignment.

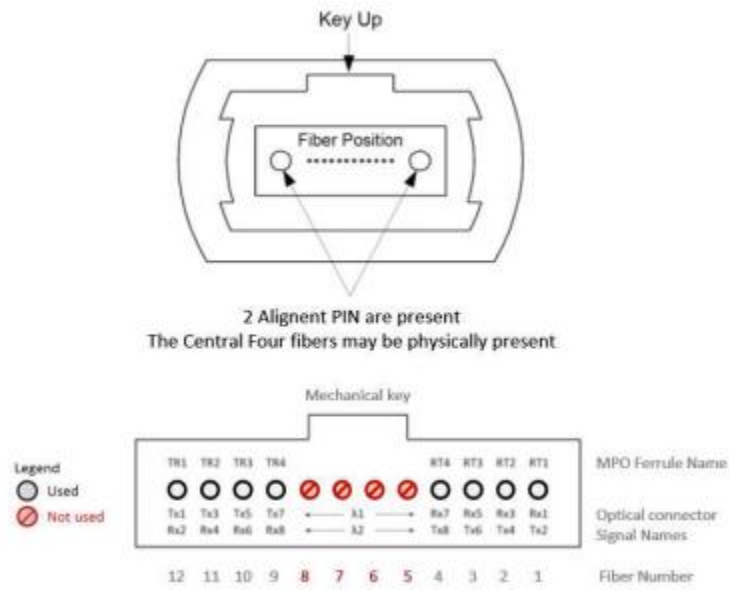

Figure 3. Outside View of the QSFDD MPO-12 Receptacle

6. Recommended Power Supply Filter

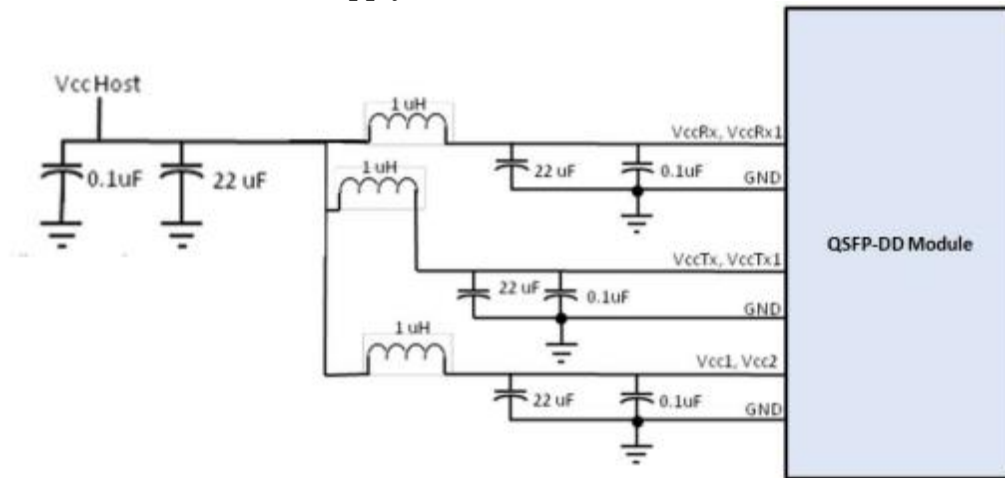

Figure 4. Recommended Power Supply Filter

7. Absolute Maximum Ratings

It has to be noted that the operation in excess of any individual absolute maximum ratings might cause permanent damage to this module.

Parameter	Symbol	Min	Max	Units	Note
Storage Temperature	T _s	-40	85	degC	
Operating Case Temperature	T _{OP}	0	70	degC	
Power Supply Voltage	V _{CC}	-0.5	3.6	V	
Relative Humidity (non-condensation)	RH	0	85	%	
Damage Threshold, each Lane	TH _a	3.4		dBm	

8. Recommended Operating Conditions and Power Supply Requirements

Parameter	Symbol	Min	Typical	Max	Units	Notes
Operating Case Temperature	T _{OP}	0		70	degC	
Power Supply Voltage	V _{CC}	3.135	3.3	3.465	V	
Data Rate, each Lane			26.5625		GBd	PAM4
Data Rate Accuracy		-100		100	ppm	
Pre-FEC Bit Error Ratio				2.4x10 ⁻⁴		
Post-FEC Bit Error Ratio				1x10 ⁻¹²		1
Link Distance with OM3	D	0.5		70	m	2

Notes:

1. FEC provided by host system.
2. FEC required on host system to support maximum distance.



9. Electrical Characteristics

The following electrical characteristics are defined over the Recommended Operating Environment unless otherwise specified.

Parameter	Test Point	Min	Typical	Max	Units	Notes
Power Consumption				12	W	
Supply Current	Icc			3.63	A	
Transmitter (each Lane)						
Signaling Rate, each Lane	TP1	26.5625 ± 100 ppm			GBd	
Differential pk-pk Input Voltage Tolerance	TP1a	900			mVpp	1
Differential Termination Mismatch	TP1			10	%	
Differential Input Return Loss	TP1	IEEE 802.3-2015 Equation (83E-5)			dB	
Differential to Common Mode Input Return Loss	TP1	IEEE 802.3-2015 Equation (83E-6)			dB	
Module Stressed Input Test	TP1a	See IEEE 802.3bs 120E.3.4.1				2
Single-ended Voltage Tolerance Range (Min)	TP1a	-0.4 to 3.3			V	
DC Common Mode Input Voltage	TP1	-350		2850	mV	3
Receiver (each Lane)						
Signaling Rate, each lane	TP4	26.5625 ± 100 ppm			GBd	
Differential Peak-to-Peak Output Voltage	TP4			900	mVpp	
AC Common Mode Output Voltage, RMS	TP4			17.5	mV	
Differential Termination Mismatch	TP4			10	%	
Differential Output Return Loss	TP4	IEEE 802.3-2015 Equation (83E-2)				

Common to Differential Mode Conversion Return Loss	TP4	IEEE 802.3-2015 Equation (83E-3)				
Transition Time, 20% to 80%	TP4	9.5			ps	
Near-end Eye Symmetry Mask Width (ESMW)	TP4		0.265		UI	
Near-end Eye Height, Differential	TP4	70			mV	
Far-end Eye Symmetry Mask Width (ESMW)	TP4		0.2		UI	
Far-end Eye Height, Differential	TP4	30			mV	
Far-end Pre-cursor ISI Ratio	TP4	-4.5		2.5	%	
Common Mode Output Voltage (Vcm)	TP4	-350		2850	mV	3

Notes:

1. With the exception to IEEE 802.3bs 120E.3.1.2 that the pattern is PRBS31Q or scrambled idle.
2. Meets BER specified in IEEE 802.3bs 120E.1.1.
3. DC common mode voltage generated by the host. Specification includes effects of ground offset voltage.

10. Optical Characteristics

Parameter	Symbol	Min	Typical	Max	Units	Notes
Transmitter						
Center Wavelength	λ_1	844		863	nm	
Center Wavelength	λ_2	900		918	nm	
RMS Spectral Width	$\Delta\lambda_{rms}$			$\lambda_1: 0.6$ $\lambda_2: 0.65$	nm	
Average Launch Power, each Lane	P_{AVG}	-6.5		4	dBm	1
Optical Modulation Amplitude (OMA), each Lane	P_{OMA}	-4.5		3	dBm	2
Launch power in OMA minus TDECQ, each lane		-5.9			dBm	

Transmitter Dispersion Penalty ,each lane	TDECQ			4.5	dB	3
TDECQ – 10log10(C _{eq}), each lane				4.5		4
Extinction Ratio	ER	3.0			dB	
RIN12 OMA				-128	dB/Hz	
Optical Return Loss Tolerance	TOL	12			dB	
Average Launch Power OFF Transmitter, each Lane	P _{off}			-30	dBm	
Encircled Flux			≥ 86% at 19 μm ≤ 30% at 4.5 μm			5
Receiver						
Signaling rate, each lane			26.5625± 100ppm		Gbps	
Center Wavelength Lane0	λ ₁	844		863	nm	
Center Wavelength Lane1	λ ₂	900		918	nm	
Damage Threshold, each Lane	TH _d	5			dBm	6
Average Receive Power, each Lane		-8.5		4	dBm	7
Receive Power (OMA), each Lane				3.0	dBm	
Receiver Sensitivity (OMA), each Lane	SEN			Max (-6.6, SECQ – 8) Refer to Figure 5	dBm	9
Receiver Reflectance	R _R			-12	dB	
Stressed receiver sensitivity in OMA, each lane				-3.5	dBm	8

Notes:

1. Average launch power, each lane (min) is informative and not the principal indicator of signal strength. A transmitter with launch power below this value cannot be compliant; however, a value above this does not ensure compliance.

2. Even if the TDECQ < 1.4 dB, the OMA_{outer} (min) must exceed this value.
3. TDECq is specified and measured as per IEEE802.3.cm Clause 150.8.5.
4. Ceq is a coefficient defined in IEEE 802.3-2018 Clause 121.8.5.8, which accounts for the reference equalizer noise enhancement.
5. If measured into type A1a.2, or type A1a.3, or type A1a.4, 50 um fibers in accordance with IEC 61280-1-4.
6. The receiver shall be able to tolerate, without damage, continuous exposure to an optical input signal having this average power level on one lane. The receiver does not have to operate correctly at this input power.
7. Average receive power, each lane (min) is informative and not the principal indicator of signal strength. A received power below this value cannot be compliant; however, a value above this does not ensure compliance.
8. Measured with a conformance test signal at TP3 (see IEEE 802.3 Cl 150) for the BER specified. They are not characteristics of the receiver. The conditions for measuring stressed receiver sensitivity are the following:

Stressed eye closure (SECQ), lane under test	4.5	dB
SECQ – 10log ₁₀ (Ceq) lane under test (max)	4.5	dBm
OMA _{outer} of each aggressor lane	3.0	dBm

These test conditions are for measuring stressed receiver sensitivity.

9. Receiver sensitivity is considered a normative requirement. RX sensitivity is defined for a transmitter with a value of SECQ up to 4.5dB. For transmitter with SECQ different from 4.5dB, limit is reported as per figure 5

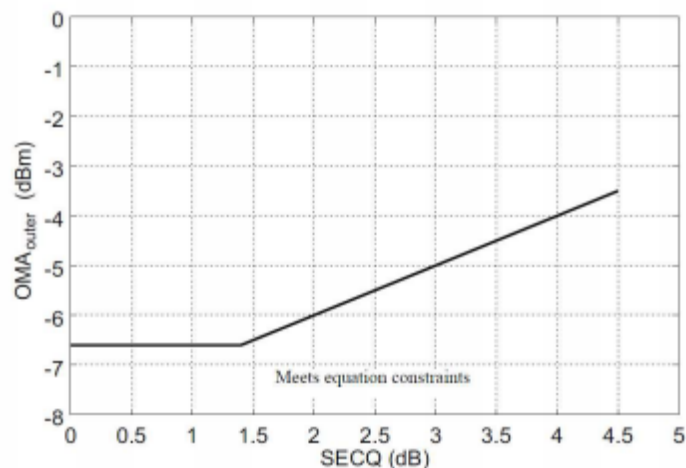

Figure 5. RX sensitivity

12. Mechanical Dimensions

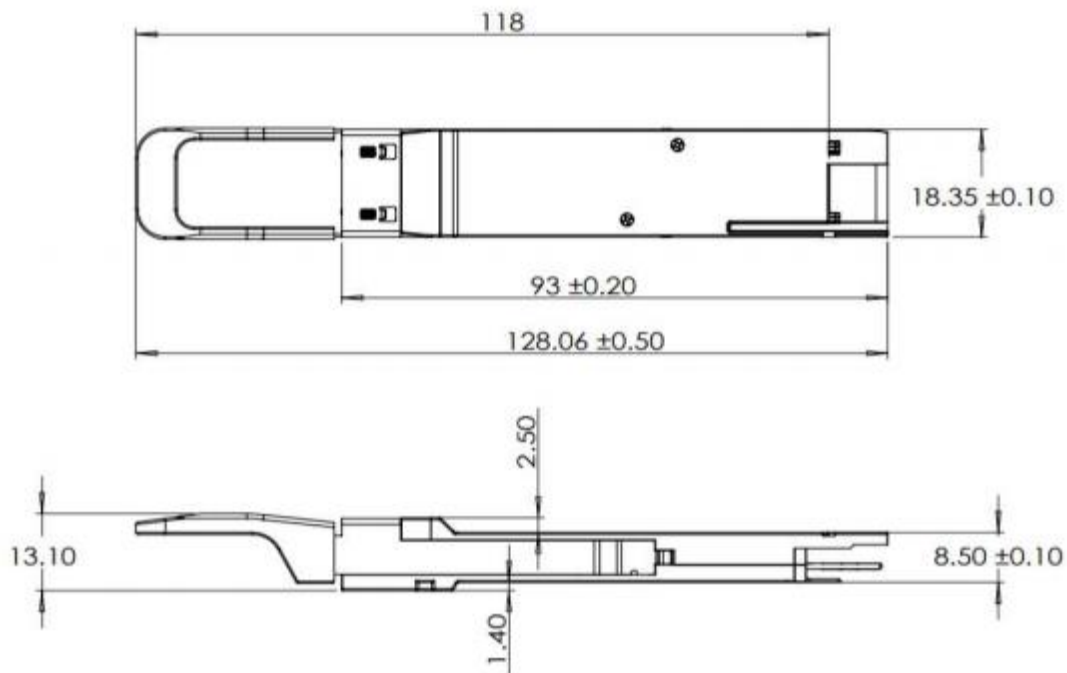

Figure 6. Mechanical Outline

13. ESD

This transceiver is specified as ESD threshold 1kV for high speed data pins and 2kV for all others electrical input pins, tested per MIL-STD-883, Method 3015.4 /JESD22-A114-A (HBM). However, normal ESD precautions are still required during the handling of this module. This transceiver is shipped in ESD protective packaging. It should be removed from the packaging and handled only in an ESD protected environment.

14. Laser Safety

This is a Class 1M Laser Product according to EN 60825-1:2014. This product complies with 21 CFR 1040.10 except for deviations pursuant to Laser Notice No. 50, dated (June 24, 2007).

Caution: Use of controls or adjustments or performance of procedures other than those specified herein may result in hazardous radiation exposure.

