

# DO-LYxxX-40

## SFP28 25Gb/s LAN-WDM 40km Transceiver

### PRODUCT FEATURES

- Up to 25.78Gbps Data Links
- Hot-pluggable SFP28 footprint
- Duplex LC connector
- LAN-WDM COOL DFB Laser and APD receiver
- Up to 40km transmission on SMF
- Metal enclosure, for lower EMI
- 2-wire interface with integrated Digital Diagnostic monitoring
- Single 3.3V power supply
- Power dissipation < 2W
- Case operating temperature :

Commercial: 0°C to +70°C

Industrial: -40°C to +85°C

### APPLICATIONS

- 25G Ethernet
- CPRI 10

### STANDARD

- Compliant to SFF-8431
- Compliant to SFF 8472
- Compliant to IEEE 802.3 CC
- RoHS Compliant.

## PRODUCT DESCRIPTION

DO-LYxxX-40 Small Form Factor Pluggable (SFP) transceivers are compatible with the SFP28 Multi-Sourcing Agreement (MSA). The module data link up to 40KM in 9/125um single mode fiber.

The optical output can be disabled by a TTL logic high-level input of Tx Disable. Tx Fault is provided to indicate that degradation of the laser. Loss of signal (LOS) output is provided to indicate the loss of an input optical signal of receiver or the link status with partner.

## Product Selection

DO-LYxxX-40, xx is the channel number for LAN WDM wavelength.

Channel	Central Wavelength	Channel	Central Wavelength
L7	1295.56	L9	1304.58
L8	1300.05	L10	1309.14

## Absolute Maximum Ratings

Parameter	Symbol	Min.	Typ.	Max.	Unit	Note
Storage Temperature	T <sub>s</sub>	-40	-	85	°C	
Relative Humidity	R <sub>H</sub>	5	-	95	%	
Power Supply Voltage	V <sub>CC</sub>	-0.3	-	4	V	
Signal Input Voltage	V <sub>SI</sub>	V <sub>CC</sub> -0.3	-	V <sub>CC</sub> +0.3	V	

## Recommended Operating Conditions

Parameter	Symbol	Min.	Typ.	Max.	Unit	Note
Case Operating Temperature	T <sub>case</sub>	0	-	70	°C	Commercial
		-40		85	°C	Industrial
Power Supply Voltage	V <sub>CC</sub>	3.14	3.3	3.47	V	
Power Supply Current	I <sub>CC</sub>	-		550	mA	Commercial
				600	mA	Industrial
Data Rate	BR		25.78		Gbps	TX Rate/RX Rate
Transmission Distance	TD		40		km	
Coupled fiber	Single mode fiber					9/125um SMF

## Optical Characteristics

Parameter	Symbol	Min.	Typ.	Max.	Unit	Note
<b>Transmitter</b>						
Average Launched Power	$P_o$	+2		+7	dBm	
Center Wavelength Range	$\lambda_C$	$\lambda-1.0$	-	$\lambda+1.0$	nm	Refer to production
Average Launched Power(Laser Off)	$P_{off}$	-	-	-30	dBm	
Spectrum Bandwidth(-20dB)	$\Delta\lambda$	-	-	0.5	nm	
Side-Mode Suppression Ratio	SMSR	30	-	-	dB	
Extinction Ratio	ER	3.5		-	dB	
Output Eye Mask	Compliant with IEEE 802.3cc					
<b>Receiver</b>						
Input Optical Wavelength	$\lambda_{IN}$	1268.23	-	1319.35	nm	
Receiver Sensitivity-AVG	$P_{Sens}$			-19	dBm	Note (1)
Receiver Sensitivity-OMA	$P_{Sens-OMA}$			-18.2	dBm	Note(1)
Input Saturation Power (Overload)	$P_{SAT}$	-4	-	-	dBm	Note (1)
Receiver Reflectance				-26	dB	
Los Of Signal Assert	$P_A$	-30	-	-	dBm	
Los Of Signal De-assert	$P_D$	-	-	-20	dBm	
LOS -Hysteresis	$P_{Hys}$	0.5			dB	

Note:

(1): BER  $\leq 5 \times 10^{-5}$

## Pin Description

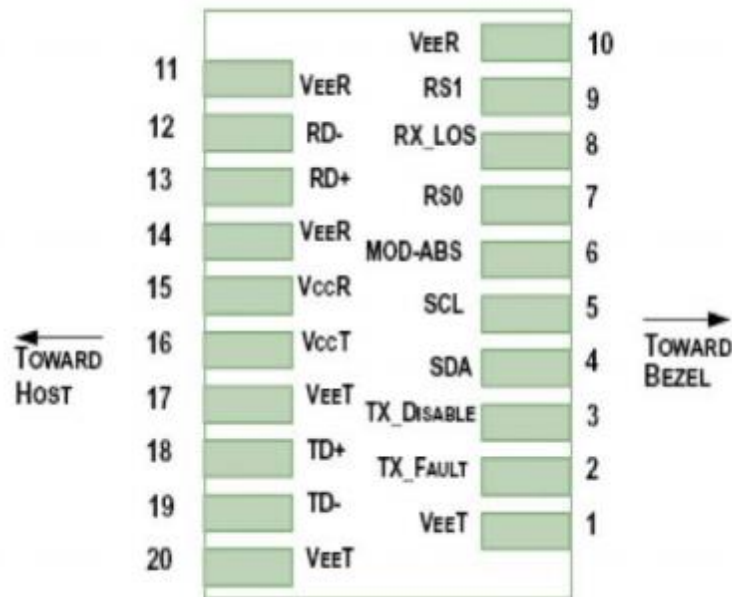

Diagram of Host Board Connector Block Pin Numbers and Name

Pin	Symbol	Name/Description	NOTE
1	$V_{EET}$	Transmitter Ground (Common with Receiver Ground)	1
2	$T_{FAULT}$	Transmitter Fault.	2
3	$T_{DIS}$	Transmitter Disable. Laser output disabled on high or open.	3
4	SDA	2-wire Serial Interface Data Line	4
5	SCL	2-wire Serial Interface Clock Line	4
6	MOD_ABS	Module Absent. Grounded within the module	4
7	RS0	Rate Select 0	5
8	LOS	Loss of Signal indication. Logic 0 indicates normal operation.	6
9	RS1	No connection required	1
10	$V_{EER}$	Receiver Ground (Common with Transmitter Ground)	1
11	$V_{EER}$	Receiver Ground (Common with Transmitter Ground)	1
12	RD-	Receiver Inverted DATA out. AC Coupled	
13	RD+	Receiver Non-inverted DATA out. AC Coupled	
14	$V_{EER}$	Receiver Ground (Common with Transmitter Ground)	1
15	$V_{CCR}$	Receiver Power Supply	
16	$V_{CCT}$	Transmitter Power Supply	
17	$V_{EET}$	Transmitter Ground (Common with Receiver Ground)	1
18	TD+	Transmitter Non-Inverted DATA in. AC Coupled.	

Pin	Symbol	Name/Description	NOTE
19	TD-	Transmitter Inverted DATA in. AC Coupled.	
20	V <sub>EET</sub>	Transmitter Ground (Common with Receiver Ground)	1

**Notes:**

1. Circuit ground is internally isolated from chassis ground.
2. TFAULT is an open collector/drain output, which should be pulled up with a 4.7k – 10k Ohms resistor on the host board if intended for use. Pull up voltage should be between 2.0V to Vcc + 0.3V. A high output indicates a transmitter fault caused by either the TX bias current or the TX output power exceeding the preset alarm thresholds. A low output indicates normal operation. In the low state, the output is pulled to <0.8V.
3. Laser output disabled on TDIS>2.0V or open, enabled on TDIS<0.8V.
4. Should be pulled up with 4.7kΩ- 10kΩ host board to a voltage between 2.0V and 3.6V. MOD\_ABS pulls line low to indicate module is plugged in.
5. Internally pulled down per SFF-8431 Rev 4.1.
6. LOS is open collector output. It should be pulled up with 4.7kΩ – 10kΩ on host board to a voltage between 2.0V and 3.6V. Logic 0 indicates normal operation; logic 1 indicates loss of signal.

**Block Diagram of Transceiver**

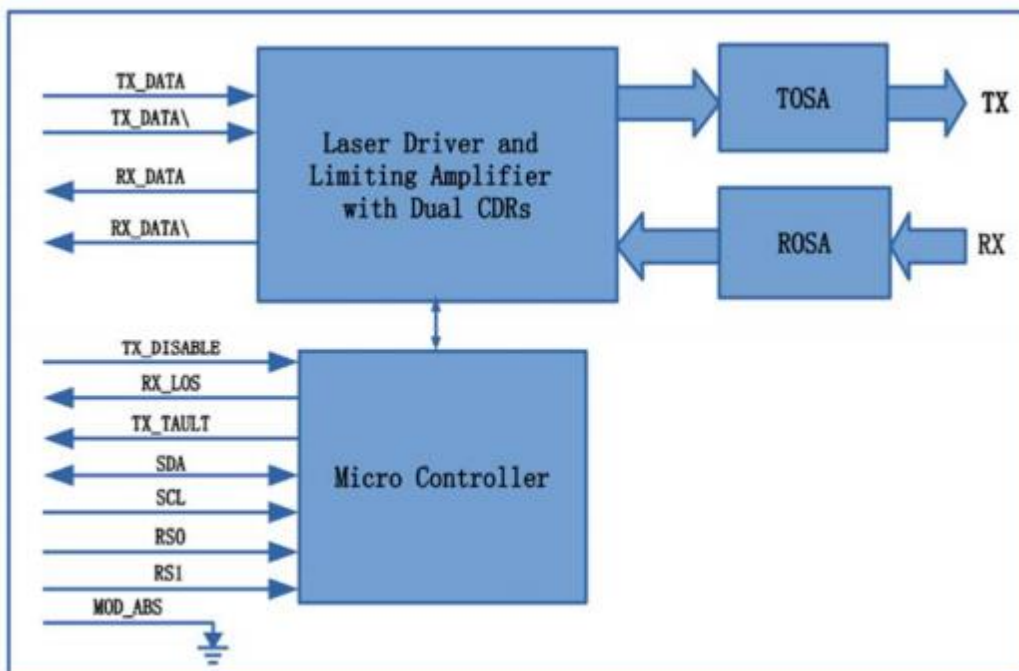

### Recommended Interface Circuit

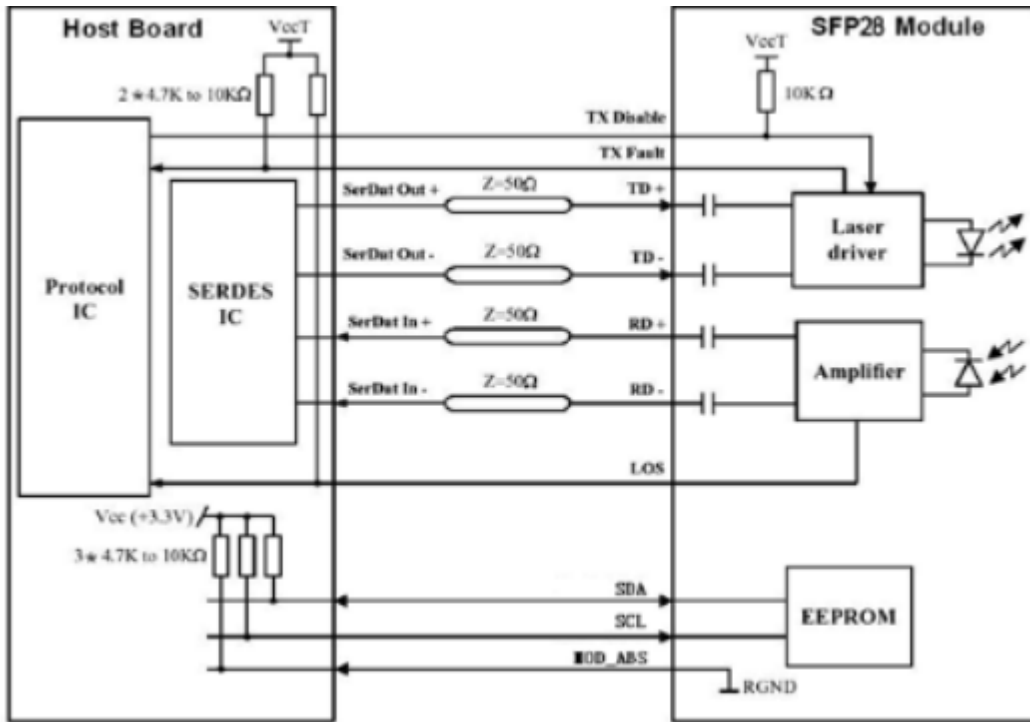

### Outline Dimensions

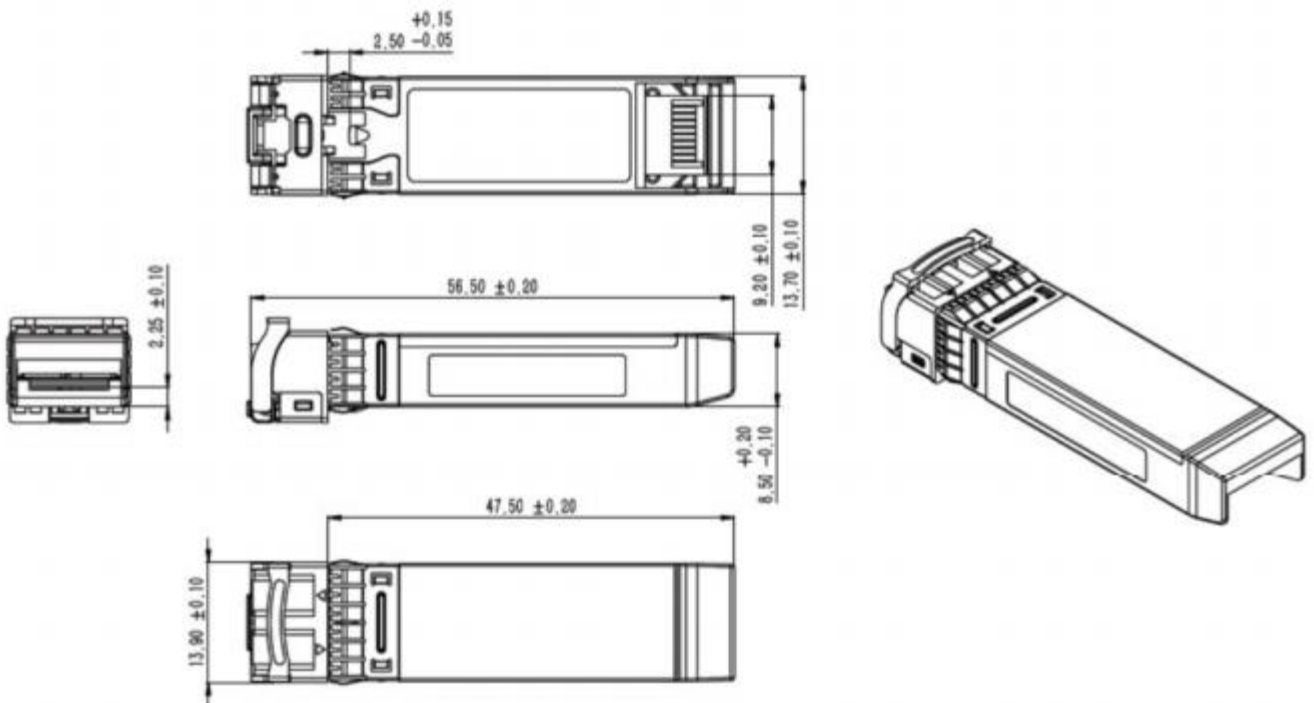

## Document Revision

Version No.	Date	Description
1.0	2018-09-06	Initial release
1.1	2019-10-25	Update LanWDM 12CH datasheet
1.2	2020-05-08	Update DML version
1.3	2020-12-10	Update L7~L10 for 40km