



XGPON1-OLT-SN1

T9.95G/R2.5G N1 SFP+ XGPON OLT Transceiver

T1577nm/R1270nm

Product Features

- ❖ Single fiber bi-directional data links TX 9.953Gbps/ Burst Mode RX 2.488Gbps application
- ❖ 3.3V power supply
- ❖ SFP+ package with SC/UPC Receptacle connector
- ❖ Hot-pluggable capability
- ❖ High power 1577nm EML DFB LD
- ❖ High sensitivity 1270nm APD
- ❖ Support 20km transmission distance with SMF
- ❖ Low EMI and excellent ESD protection
- ❖ Digital diagnostic monitor interface
- ❖ 0 to 70°C operating case temperature

Applications

- ❖ XG-PON OLT SFP N1

Standards

- ❖ Complies with SFF-8431
- ❖ Complies with SFF-8432
- ❖ Complies with SFF-8472



do
networks

- ❖ Complies with ITU-T G.987.2
- ❖ Complies with FCC 47 CFR Part 15, Class B
- ❖ Complies with FDA 21 CFR 1040.10 and 1040.11

Absolute Maximum Ratings

Parameter	Symbol	Min	Max	Unit	Notes
Storage Ambient Temperature	T _{STG}	-40	+85	°C	
Operating Case Temperature	T _C	0	+70	°C	
Operating Humidity	OH	5	85	%	
VCC3 Power Supply Voltage	VCC	0	3.6	V	

Recommended Operating Conditions

Parameter	Symbol	Min	Typical	Max	Unit
Operating Case Temperature	T _C	0		+70	°C
VCC3 Power Supply Voltage	V _{CC}	3.13	3.3	3.47	V
VCC3 Power Supply Current	I _{CC}		-	550	mA
Date Rate			9.953/2.488		Gbps
Date Rate Drift		-100		+100	PPM

Transmitter Optical Characteristics

Parameter	Symbol	Min	Typical	Max	Unit	Notes
Optical Center Wavelength	λ_C	1575		1580	nm	
Optical Spectrum Width (-20dB)	$\Delta\lambda$	-	-	1	nm	



Side Mode Suppression Ratio	SMSR	30			dB	
Average Launch Optical Power (BOL)	AOP	+2.5		+6	dBm	Launched into SMF @ Room Temperature
Average Launch Optical Power (EOL)	AOP	+2		+6	dBm	Launched into SMF @ 0~70 °C
Power-OFF Transmitter Optical Power				-39	dBm	Launched into SMF
Extinction Ratio	ER	8.2			dB	PRBS ²³¹ -1
Transmitter Reflectance				-10	dB	
Transmitter Tolerance to Reflected Optical Power		-15			dB	
Transmitter and Dispersion Penalty	TDP			1	dB	Transmit on 20km SMF
Optical Waveform Diagram	Compliant with ITU-T 987.2					Figure 1, Mask Margin>5%

Transmitter Electrical Characteristics

Parameter	Symbol	Min	Typical	Max	Unit	Notes
Data Input Differential Swing		120		820	mV	CML input, AC coupled
Input Differential Impedance		80	100	120	Ω	
Transmitter Disable Voltage - Low		0		0.8	V	Transmitter On
Transmitter Disable Voltage - High		2.0		V _{cc}	V	Transmitter Off
Transmitter Fault Voltage - Low		0		0.4	V	Transmitter On
Transmitter Fault Voltage - High		2.4		V _{cc}	V	Transmitter Fault

Transmitter Eye Mask Definitions and Test Procedure

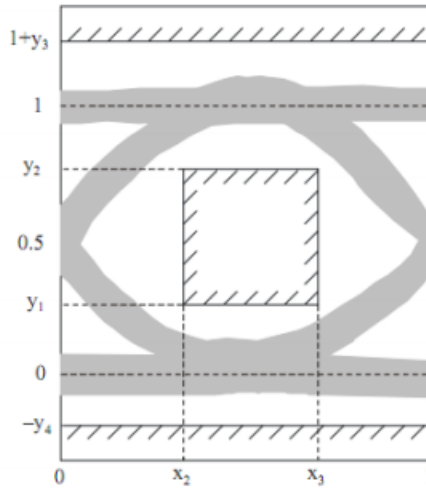

Figure 1: XGPON Transmitter Eye Mask Definitions

X3-X2	Y1	Y2	Y3	Y4	Unit
0.2	0.25	0.75	0.25	0.25	UI

Receiver Optical Characteristics

Parameter	Symbol	Min	Typical	Max	Unit	Notes
Operating Wavelength		1260		1280	nm	
Sensitivity	SEN (BOL)			-28.5	dBm	PRBS 2 ²³ -1 @2.488Gbps BER ≤1×10 ⁻⁴
	SEN (EOL)			-27.5	dBm	
Saturation Optical Power	SAT	-7			dBm	
Burst Dynamic Range		15			dB	
Signal Detect Assert	SDA			-29.5	dBm	
Signal Detect De-assert	ADD	-45			dBm	
Signal Detect Hysteresis		0.5		7.5	dB	
Receiver Reflectance				-20	dB	



networks

Receiver Electrical Characteristics

Parameter	Symbol	Min	Typical	Max	Unit	Notes
Data Output Differential Swing		340		850	mV	CML Output, AC coupled
Reset width	Trw	25.6			ns	Figure 2
Signal Detect Assert Time	Tsda1			50	ns	Figure 2
Signal Detect Assert Time	Tsda2			50	ns	Figure 2
Signal Detect De-assert Time	Tsdd			12.8	ns	Figure 2
Data Recovery Time	Trec			25.6	ns	Figure 2
Reset To ONU Optical Time	Trto	0		250	us	Figure 2
Reset Guard Time	Trg	0		250	us	Figure 2
Reset-Low		0		0.8	V	
Reset-High		2.0		Vcc	V	
Signal Detect Voltage-Low		0		0.6	V	
Signal Detect Voltage-High		2.4		Vcc	V	
RSSI Trigger-Low		0		0.8	V	

RSSI Trigger-High		2.0		Vcc	V	
Upstream Signal Width	T _{ONT}	550			ns	Figure 4
RSSI Trigger Delay	T _D	25			ns	Figure 4
RSSI Trigger Width	T _w	500			ns	Figure 4
I ² C Access Prohibited Time	T _P	500			μs	Figure 4

Timing Parameter Definitions in Burst Mode Sequence

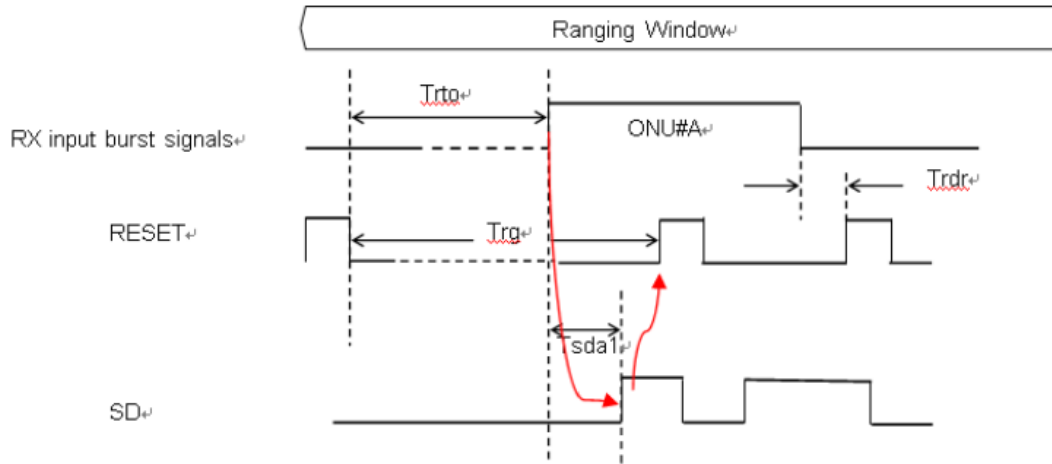

Timing requirements of ranging period

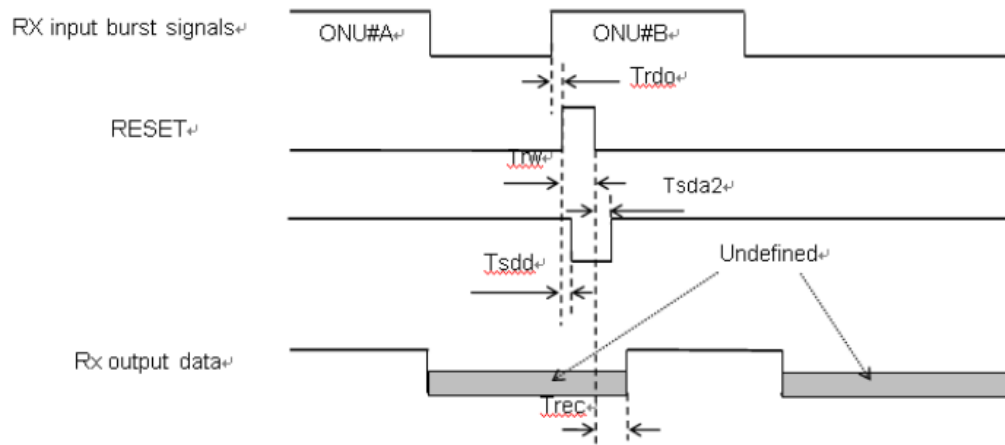

Timing requirements of normal operating

Figure 2: Timing Parameter Definitions in Burst Mode Sequence

Burst Mode Receiver Dynamic Range

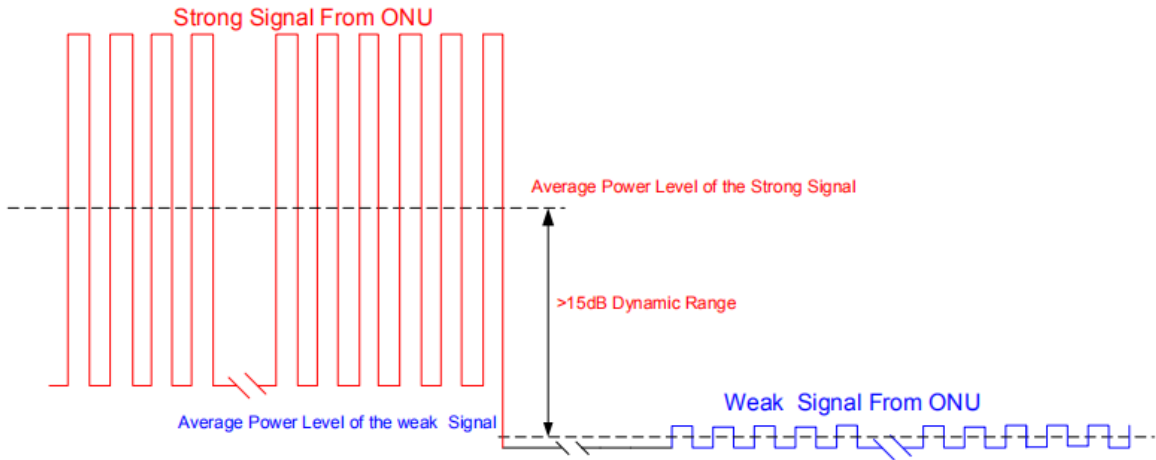

Figure 3: Burst Mode Receiver Dynamic Range in XGPON System

Timing Parameter Definitions in RSSI Trigger

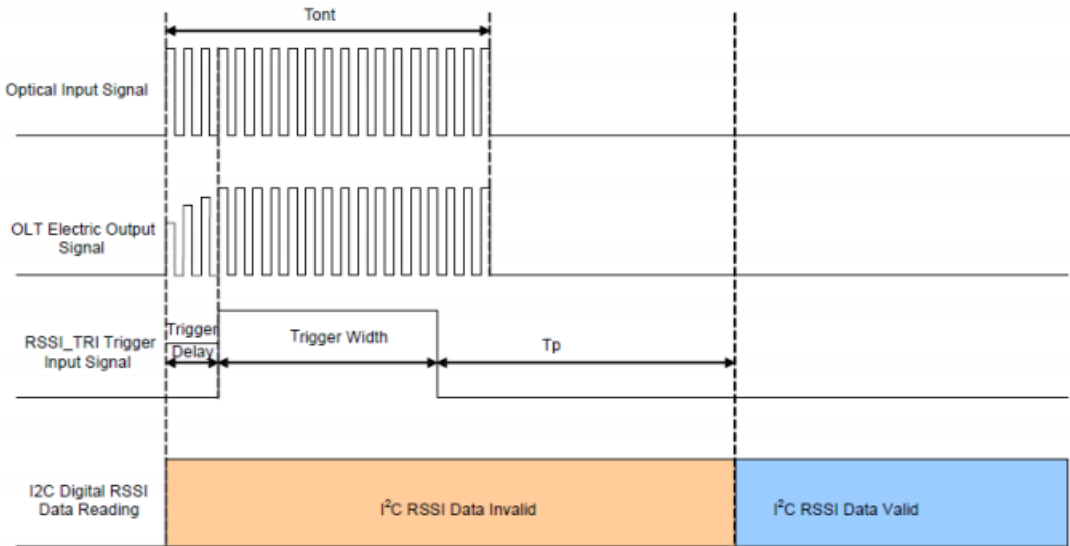

Figure 4 Timing Parameter Definitions in RSSI Trigger



networks

Pin Description

PIN	Name	Description	Notes
1	VEET	Transmitter Ground	
2	TX Fault	Transmitter Fault Indication	LVTTTL, High Indicates TX Laser Fault
3	TX Disable	Transmitter Disable	LVTTTL, Low: transmitter on
4	SDA	The data line	The data line of two wire serial interface
5	SCL	The clock line	The clock line of two wire serial interface
6	MOD_DEF0	Module definition 0	Grounded in module
7	Reset	Burst Receiver Reset	LVTTTL, High level Reset
8	SD	SD output	LVTTTL, High active
9	RSSI_TRIG	RSSI trigger for Transceiver A/D converter	LVTTTL, High active
10	VEER	Receiver Ground	
11	VEER	Receiver Ground	
12	RD-	Inverted Received Data Out	CML Output, AC coupled
13	RD+	Non-inverted Received Data Out	CML Output, AC coupled
14	VEER	Receiver ground	
15	VCCR	Receiver 3.3V Power Supply	
16	VCCT	Transmitter 3.3V Power Supply	
17	VEET	Transmitter Ground	
18	TD+	Non-inverted Transmitter Data in	CML Input, AC coupled
19	TD-	Inverted Transmitter Data in	CML Input, AC coupled
20	VEET	Transmitter Ground	



networks

Pin Out Drawing

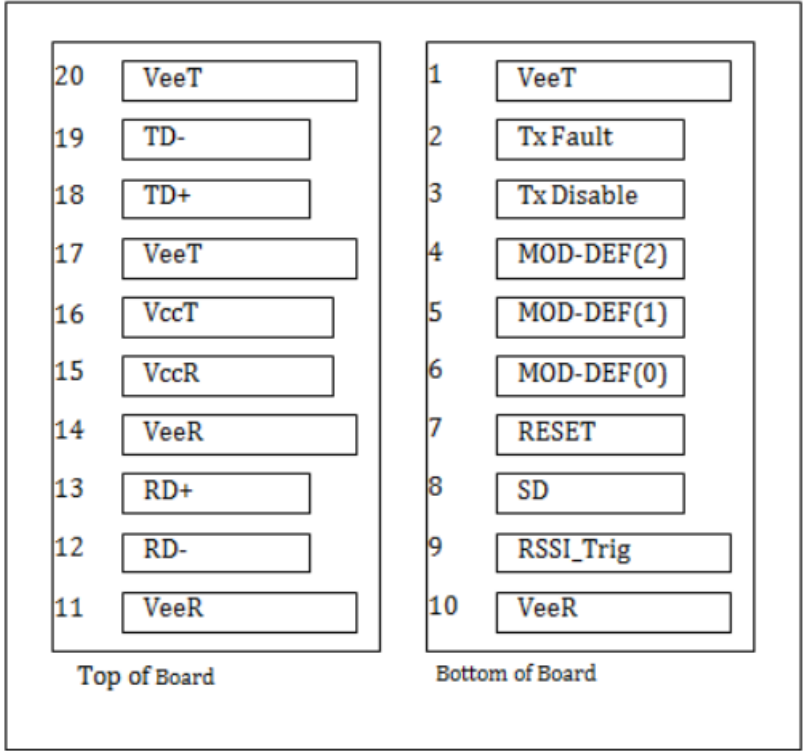

Figure 5: Pin Out Drawing



networks

Typical Interface Circuit

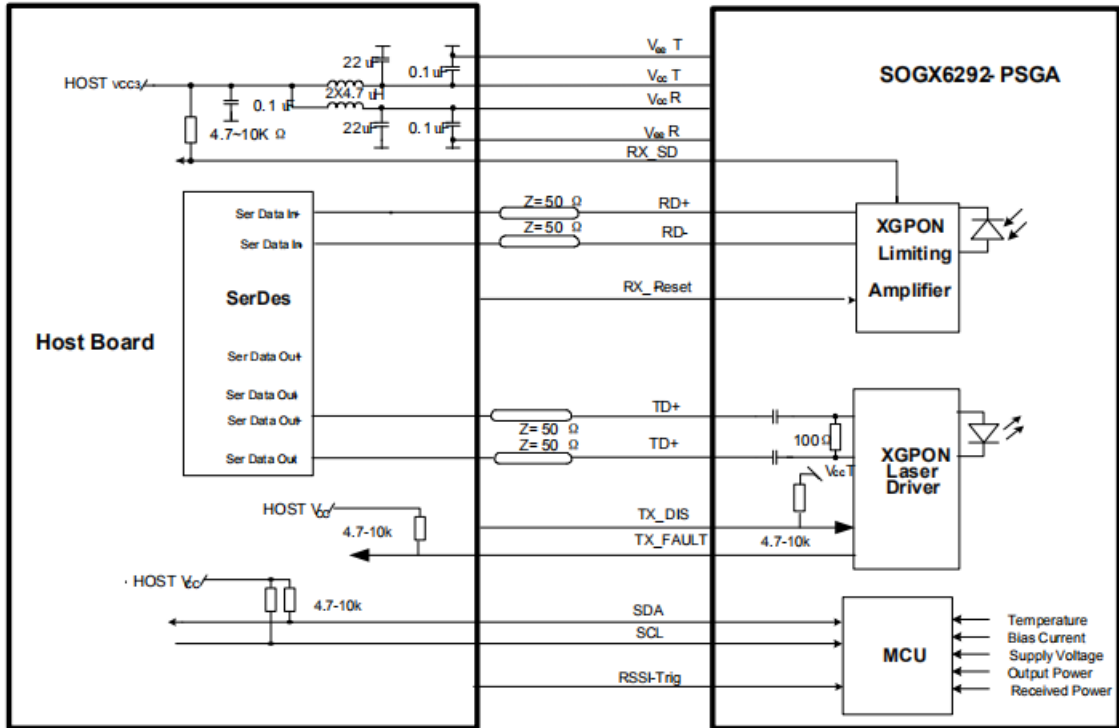
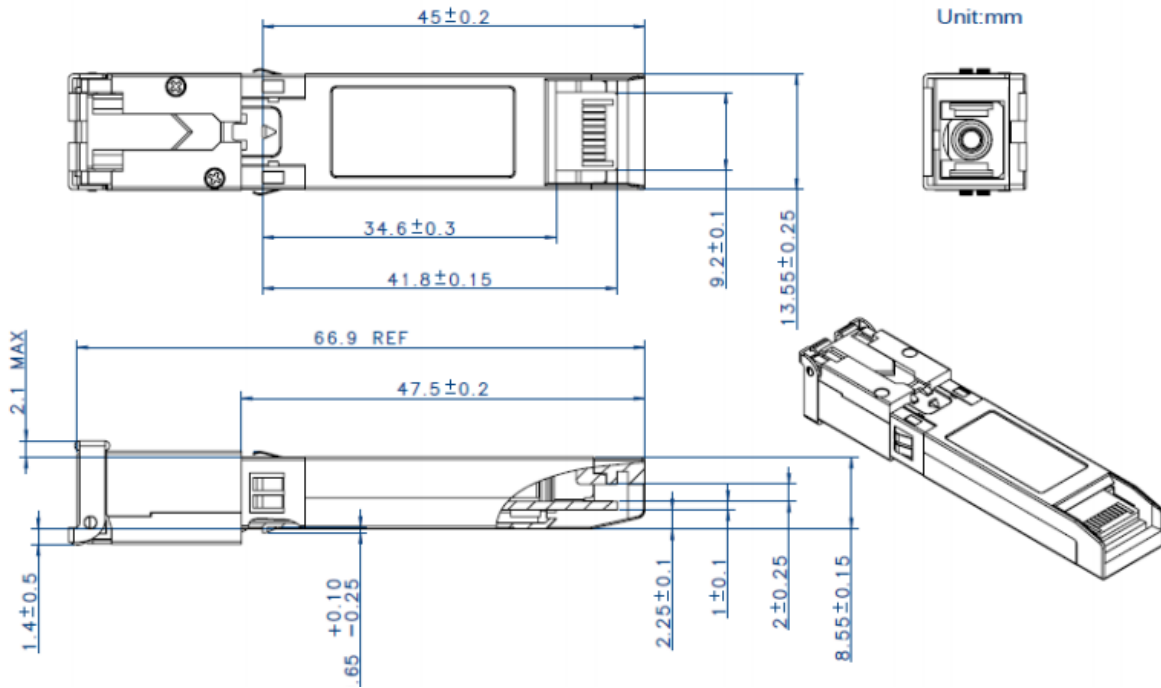

Figure 6: Typical Interface Circuit



networks

Package Outline



Ordering Information

Part Number	Product Description
XGPON1-OLT-SN1	XG-PON1 OLT T9.95G/R2.5G T1577nm/R1270nm N1 SFP+ 0° C~+70° C