



100Gb/s QSFP28 ER4 Transceiver QSFP28-100G-ER4-x

Features

- Compliant to Ethernet 100GBASE-ER4
- Support line rates from 103.125 Gb/s to 111.81 Gb/s
- Transmitter: cooled 4x28Gb/s LAN WDM EML TOSA (1295.56, 1300.05, 1304.58, 1309.14nm)
- Receiver: 4x28Gb/s APD ROSA
- Up to 40km reach for G.652 SMF
- Duplex LC optical receptacle
- 4x28G electrical interface (OIF CEI-28G-VSR)
- RoHS-10 compliant and lead-free
- Single +3.3V power supply
- Maximum power consumption 4.5W
- Case operating temperature
Commercial: 0 ~ +70°C
Extended: -10 ~ +80°C
Industrial: -40 ~ +85°C

Applications

- 100GBASE-ER4 Ethernet Links
- Infiniband QDR and DDR interconnects
- Client-side 100G Telecom connections

Address : Room 426 Bu,No.4 Building, 1st. Software Park, Keji Middle 3rd, Middle Zone, Hi-Tech Park,Shenzhen,China

Tel: +86-755-26819856

Web: www.do-networks.com

V1.0



Part Number Ordering Information

Part Number	Data Rate (Gb/s)	Wavelength (nm)	Transmission Distance(km)	Temperature (°C) (Operating Case)
QSFP28-100G-ER4-C	103.1/112	1295.56, 1300.05, 1304.58, 1309.14	40	0~70 commercial
QSFP28-100G-ER4-E	103.1/112	1295.56, 1300.05, 1304.58, 1309.14	40	-10~80 Extended
QSFP28-100G-ER4-I	103.1/112	1295.56, 1300.05, 1304.58, 1309.14	40	-40~85 Industrial

I. Absolute Maximum Ratings

It has to be noted that the operation in excess of any individual absolute maximum ratings might cause permanent damage to this module.

Parameter	Symbol	Min	Max	Unit	Notes
Storage Temperature	T _s	-40	85	°C	
Power Supply Voltage	V _{CC}	-0.3	4.0	V	
Relative Humidity (non-condensation)	RH	0	85	%	
Damage Threshold	TH _d	-3.0		dBm	

II. Recommended Operating Conditions

Parameter	Symbol	Min	Typical	Max	Unit	Notes
Operating Case Temperature	T _{OP}	0		70	°C	commercial
		-10		80		extended
		-40		85		Industrial
Power Supply Voltage	V _{CC}	3.135	3.3	3.465	V	
Data Rate, each Lane			25.78125	28.05	Gb/s	
Control Input Voltage High		2		V _{CC}	V	
Control Input Voltage Low		0		0.8	V	
Link Distance (SMF)	D			40	km	1

Address : Room 426 Bu,No.4 Building, 1st. Software Park, Keji Middle 3rd, Middle Zone, Hi-Tech Park,Shenzhen,China

Tel: +86-755-26819856

Web: www.do-networks.com

V1.0



Notes:

1. Depending on actual fiber loss/km (link distance specified is for fiber insertion loss of 0.35dB/km)

III. General Description

This product is a 100/112Gb/s transceiver module designed for optical communication applications compliant to Ethernet 100GBASE-ER4 standard. The module converts 4 input channels of 25/28Gb/s electrical data to 4 channels of LAN WDM optical signals and then multiplexes them into a single channel for 100/112Gb/s optical transmission. Reverse on the receiver side, the module de-multiplexes a 100/112Gb/s optical input into 4 channels of LAN WDM optical signals and then converts them to 4 output channels of electrical data.

The central wavelengths of the 4 LAN WDM channels are 1295.56, 1300.05, 1304.58 and 1309.14 nm as members of the LAN WDM wavelength grid defined in IEEE 802.3ba. The high-performance cooled LAN WDM EA-DFB transmitters and high sensitivity APD receivers provide superior performance for 100Gigabit Ethernet applications up to 40km links.

The product is designed with form factor, optical/electrical connection and digital diagnostic interface according to the QSFP+ Multi-Source Agreement (MSA). It has been designed to meet the harshest external operating conditions including temperature, humidity and EMI interference.

IV. Functional Description

The transceiver module receives 4 channels of 25/28Gb/s electrical data, which are processed by a 4-channel Clock and Data Recovery (CDR) IC that reshapes and reduces the jitter of each electrical signal. Subsequently, EML laser driver IC converts each one of the 4 channels of electrical signals to an optical signal that is transmitted from one of the 4 cooled EML lasers which are packaged in the Transmitter Optical Sub-Assembly (TOSA). Each laser launches the optical signal in specific wavelength specified in IEEE 802.3ba 100GBASE-ER4 requirements. These 4-lane optical signals will be optically multiplexed into a single fiber by a 4-to-1 optical WDM MUX. The optical output power of each channel is maintained constant by an automatic power control (APC) circuit. The transmitter output can be turned off by TX_DIS hardware signal and/or 2-wire serial interface.

The receiver receives 4-lane LAN WDM optical signals. The optical signals are de-multiplexed by a 1-to-4 optical DEMUX and each of the resulting 4 channels of optical signals is fed into one of the 4 receivers that are packaged into the Receiver Optical Sub-Assembly (ROSA). Each receiver converts the optical signal to an electrical signal. The regenerated electrical signals are retimed and de-jittered and amplified by the RX portion of the 4-channel CDR. The retimed 4-lane output electrical signals are compliant with CEI-28G-VSR interface requirements. In addition, each received optical signal is monitored by the DOM section. The monitored value is reported through the 2-wire serial interface. If one or more received optical signal is weaker than the

Address : Room 426 Bu,No.4 Building, 1st. Software Park, KeJi Middle 3rd, Middle Zone, Hi-Tech Park,Shenzhen,China

Tel: +86-755-26819856

Web: www.do-networks.com

V1.0



threshold level, RX_LOS hardware alarm will be triggered.

A single +3.3V power supply is required to power up this product. Both power supply pins VccTx and VccRx are internally connected and should be applied concurrently. As per MSA specifications the module offers 7 low speed hardware control pins (including the 2-wire serial interface): ModSelL, SCL, SDA, ResetL, LPMODE, ModPrsL and IntL.

Module Select (ModSelL) is an input pin. When held low by the host, this product responds to 2-wire serial communication commands. The ModSelL allows the use of this product on a single 2-wire interface bus – individual ModSelL lines must be used.

Serial Clock (SCL) and Serial Data (SDA) are required for the 2-wire serial bus communication interface and enable the host to access the QSFP28 memory map.

The ResetL pin enables a complete reset, returning the settings to their default state, when a low level on the ResetL pin is held for longer than the minimum pulse length. During the execution of a reset the host shall disregard all status bits until it indicates a completion of the reset interrupt. The product indicates this by posting an IntL (Interrupt) signal with the Data_Not_Ready bit negated in the memory map. Note that on power up (including hot insertion) the module should post this completion of reset interrupt without requiring a reset.

Low Power Mode (LPMODE) pin is used to set the maximum power consumption for the product in order to protect hosts that are not capable of cooling higher power modules, should such modules be accidentally inserted.

Module Present (ModPrsL) is a signal local to the host board which, in the absence of a product, is normally pulled up to the host Vcc. When the product is inserted into the connector, it completes the path to ground through a resistor on the host board and asserts the signal. ModPrsL then indicates its present by setting ModPrsL to a “Low” state.

Interrupt (IntL) is an output pin. “Low” indicates a possible operational fault or a status critical to the host system. The host identifies the source of the interrupt using the 2-wire serial interface. The IntL pin is an open collector output and must be pulled to the Host Vcc voltage on the Host board.

V. Pin Assignment and Pin Description

Address : Room 426 Bu, No.4 Building, 1st. Software Park, Keji Middle 3rd, Middle Zone, Hi-Tech Park, Shenzhen, China

Tel: +86-755-26819856

Web: www.do-networks.com

V1.0

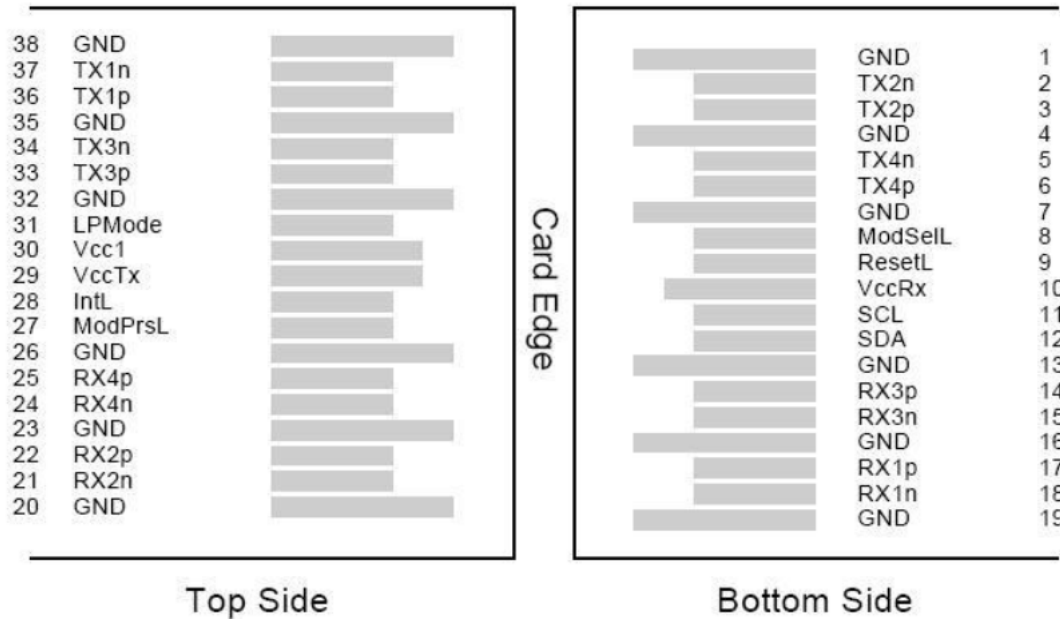

Figure1. Diagram of host board connector block pin numbers and names

Pin	Symbol	Name/Description	Notes
1	GND	Transmitter Ground (Common with Receiver Ground)	1
2	Tx2n	Transmitter Inverted Data Input	
3	Tx2p	Transmitter Non-Inverted Data output	
4	GND	Transmitter Ground (Common with Receiver Ground)	1
5	Tx4n	Transmitter Inverted Data Input	
6	Tx4p	Transmitter Non-Inverted Data output	
7	GND	Transmitter Ground (Common with Receiver Ground)	1
8	ModSelL	Module Select	
9	ResetL	Module Reset	
10	VccRx	3.3V Power Supply Receiver	2
11	SCL	2-Wire serial Interface Clock	



12	SDA	2-Wire serial Interface Data	
13	GND	Transmitter Ground (Common with Receiver Ground)	
14	Rx3p	Receiver Non-Inverted Data Output	
15	Rx3n	Receiver Inverted Data Output	
16	GND	Transmitter Ground (Common with Receiver Ground)	1
17	Rx1p	Receiver Non-Inverted Data Output	
18	Rx1n	Receiver Inverted Data Output	
19	GND	Transmitter Ground (Common with Receiver Ground)	1
20	GND	Transmitter Ground (Common with Receiver Ground)	1
21	Rx2n	Receiver Inverted Data Output	
22	Rx2p	Receiver Non-Inverted Data Output	
23	GND	Transmitter Ground (Common with Receiver Ground)	1
24	Rx4n	Receiver Inverted Data Output	1
25	Rx4p	Receiver Non-Inverted Data Output	
26	GND	Transmitter Ground (Common with Receiver Ground)	1
27	ModPrsl	Module Present	
28	IntL	Interrupt	
29	VccTx	3.3V power supply transmitter	2
30	Vcc1	3.3V power supply	2
31	LPMODE	Low Power Mode	
32	GND	Transmitter Ground (Common with Receiver Ground)	1
33	Tx3p	Transmitter Non-Inverted Data Input	
34	Tx3n	Transmitter Inverted Data Output	

Address : Room 426 Bu,No.4 Building, 1st. Software Park, Keji Middle 3rd, Middle Zone, Hi-Tech Park,Shenzhen,China

Tel: +86-755-26819856

Web: www.do-networks.com

V1.0



35	GND	Transmitter Ground (Common with Receiver Ground)	1
36	Tx1p	Transmitter Non-Inverted Data Input	
37	Tx1n	Transmitter Inverted Data Output	
38	GND	Transmitter Ground (Common with Receiver Ground)	1

Notes:

1. GND is the symbol for signal and supply (power) common for QSFP28 modules. All are common within the QSFP28 module and all module voltages are referenced to this potential unless otherwise noted. Connect these directly to the host board signal common ground plane.
2. VccRx, VccI and VccTx are the receiving and transmission power suppliers and shall be applied concurrently. Recommended host board power supply filtering is shown below. Vcc Rx, VccI and Vcc Tx may be internally connected within the QSFP28 transceiver module in any combination. The connector pins are each rated for a maximum current of 1000mA.

VI. Electrical Characteristics

The following electrical characteristics are defined over the Recommended Operating Environment unless otherwise specified.

Parameter	Symbol	Min.	Typ.	Max	Unit	Notes
Power Consumption	p			4.5	W	
Supply Current	Icc			1360	mA	
Transmitter (each Lane)						
Overload Differential Voltage pk-pk	TP1a	900			mV	
Common Mode Voltage (Vcm)	TP1	-350		2850	mV	1
Differential Termination Resistance Mismatch	TP1			10	%	At 1MHz
Differential Return Loss (SDD11)	TP1			See CEI-28G -VSR Equatio n 13-19	dB	

Address : Room 426 Bu,No.4 Building, 1st. Software Park, Keji Middle 3rd, Middle Zone, Hi-Tech Park,Shenzhen,China

Tel: +86-755-26819856

Web: www.do-networks.com

V1.0

Common Mode to Differential conversion and Differential to Common Mode conversion (SDC11, SCD11)	TP1			See CEI-28G -VSR Equation 13-20	dB	
Stressed Input Test	TP1a	See CEI-28G -VSR Section 13.3.11. 2.1				
Receiver						
Differential Voltage, pk-pk	TP4			900	mV	
Common Mode Voltage (Vcm)	TP4	-350		2850	mV	1
Common Mode Noise, RMS	TP4			10	%	At 1MHz
Differential Return Loss (SDD22)	TP4			See CEI-28G -VSR Equation 13-19	dB	
Common Mode to Differential conversion and Differential to Common Mode conversion (SDC22, SCD22)	TP4			See CEI-28G -VSR Equation 13-21	dB	
Common Mode Return Loss (SCC22)	TP4			-2	dB	2
Transition Time, 20 to 80%	TP4	9.5			ps	
Vertical Eye Closure (VEC)	TP4			5.5	dB	
Eye Width at 10-15 probability	TP4	0.57			UI	

Address : Room 426 Bu,No.4 Building, 1st. Software Park, Keji Middle 3rd, Middle Zone, Hi-Tech Park,Shenzhen,China

Tel: +86-755-26819856

Web: www.do-networks.com

V1.0



(EW15)						
Eye Height at 10-15 probability (EH15)	TP4	228			mV	

Notes:

1. Vcm is generated by the host. Specification includes effects of ground offset voltage.
2. From 250MHz to 30GHz.

VII. Optical Characteristics

The following optical characteristics are defined over the Recommended Operating Environment unless otherwise specified.

Parameter	Symbol	Min.	Typical	Max	Unit	Notes
Transmitter						
Lane wavelength (range)	L0	1294.53	1295.56	1296.59	nm	
	L1	1299.02	1300.05	1301.09	nm	
	L2	1303.54	1304.58	1305.63	nm	
	L3	1308.09	1309.14	1310.09	nm	
Signaling rate, each lane			25.78125	28.05	GBd	
Side-mode suppression ratio	SMSR	30				
Total launch power	P _T			10.5	dBm	
Average launch power, each lane	P _{avg}	-2.9		4.5	dBm	1
OMA, each Lane	P _{OMA}	0.1		4.5	dBm	2
Extinction Ratio	ER	8.0			dB	
Difference in Launch Power between any Two Lanes (OMA)	P _{tx,diff}			3.6	dB	
Transmitter and Dispersion Penalty, each lane	TDP			2.5	dB	

Address : Room 426 Bu,No.4 Building, 1st. Software Park, Keji Middle 3rd, Middle Zone, Hi-Tech Park,Shenzhen,China

Tel: +86-755-26819856

Web: www.do-networks.com

V1.0



OMA minus TDP, each lane	OMA-TD P	-0.65			dBm	
Average launch power of OFF transmitter, each lane	Poff			-30	dBm	
Transmitter reflectance	R _T			-12	dB	
RIN ₂₀ OMA	RIN			-130	dB/Hz	
Optical Return Loss Tolerance	TOL			20	dB	
Transmitter eye mask {X1, X2,X3, Y1, Y2, Y3}		{0.25, 0.4, 0.45, 0.25, 0.28, 0.4}				
Receiver						
Signaling rate, each lane			25.78125	28.05	GBd	
Average Receive Power, each Lane		-20		-4.9	dBm	for 40km Link Distance
Receive Power (OMA), each Lane				-1.9	dBm	
Receiver Sensitivity Average, each Lane	SEN1			-16.65	dBm	3
Receiver Sensitivity Average, each Lane	SEN2			-20.5	dBm	4
Receiver reflectance				-26	dB	
Difference in Receive Power between any Two Lanes (Average and OMA)	Ptx,diff			3.6	dB	
LOS Assert	LOSA		-26		dBm	
LOS Deassert	LOSD		-24		dBm	
LOS Hysteresis	LOSH	0.5			dB	
Receiver Electrical 3 dB	Fc			31	GHz	

Address : Room 426 Bu,No.4 Building, 1st. Software Park, KeJi Middle 3rd, Middle Zone, Hi-Tech Park,Shenzhen,China

Tel: +86-755-26819856

Web: www.do-networks.com

V1.0



upper						
Receiver Electrical 3 dB upper						
Conditions of Stress Receiver Sensitivity Test (Note 5)						
Vertical Eye Closure Penalty, each Lane			1.5		dB	
Stressed Eye J2 Jitter, each Lane			0.3		UI	
Stressed Eye J9 Jitter, each Lane			0.47		UI	

Notes:

1. The minimum average launch power spec is based on ER not exceeding 9.5dB and transmitter OMA higher than 0.1dBm.
2. Even if the TDP < 0.75 dB, the OMA min must exceed the minimum value specified here.
3. Measured with a PRBS 231-1 test pattern, @25.78Gb/s, BER<1E-12.
4. Measured with a PRBS 231-1 test pattern, @28.05Gb/s, BER<5E-5.
5. Vertical eye closure penalty, stressed eye J2 jitter, and stressed eye J9 jitter are test conditions for measuring stressed receiver sensitivity. They are not characteristics of the receiver.

VIII. Digital Diagnostic Functions

The following digital diagnostic characteristics are defined over the normal operating conditions unless otherwise specified.

Parameter	Symbol	Min.	Max	Unit	Notes
Temperature monitor absolute error	DMI_Temp	-3	3	°C	Over operating temp
Supply voltage monitor absolute error	DMI_VCC	-3	3	%	Full operating range
RX power monitor absolute error	DMI_RX	-3	3	dB	
Bias current monitor error	DMI_bias	-10	10	%	
TX power monitor absolute error	DMI_TX	-3	3	dB	

IX. Mechanical Dimensions

Address : Room 426 Bu,No.4 Building, 1st. Software Park, KeJi Middle 3rd, Middle Zone, Hi-Tech Park,Shenzhen,China

Tel: +86-755-26819856

Web: www.do-networks.com

V1.0

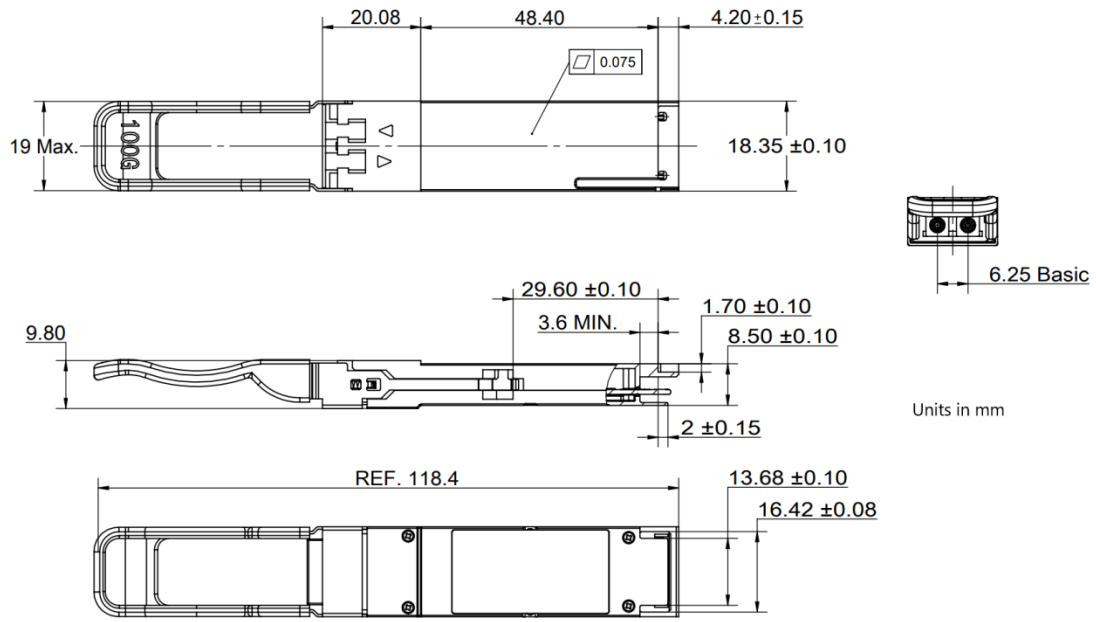

Figure2. Mechanical Outline

X. Revision History

Version No.	Initiated	Revised contents	Release Date
V1.0	Andy Zhang	Preliminary datasheet	2020-09-20