



XGSPON-OLT-XN2

XGSPON OLT XFP N2 Transceiver

Product Features

- ❖ Single fiber bi-directional data links TX 9.95Gbps, Burst Mode RX 9.95G/2.488Gbps application
- ❖ 3.3V power supply
- ❖ XFP package with SC Receptacle connector
- ❖ Hot-pluggable capability
- ❖ High power 1577nm EML LD & High sensitivity 1270nm APD
- ❖ Support 20km transmission distance with SMF
- ❖ SD indication
- ❖ Low EMI and excellent ESD protection
- ❖ Digital diagnostic monitor interface
- ❖ RoHS6 compliance
- ❖ 0 to 70°C operating case temperature

Applications

- ❖ XGS-PON XFP OLT N2

Standards

- ❖ Complies with INF-8077i
- ❖ Complies with ITU G.987.2
- ❖ Complies with FCC 47 CFR Part 15, Class B
- ❖ Complies with FDA 21 CFR 1040.10 and 1040.11

Absolute Maximum Rating

Parameter	Symbol	Min	Max	Unit	Notes
Storage Ambient Temperature	T _{STG}	-40	85	°C	
Operating Case Temperature	T _C	0	70	°C	
Operating Humidity	OH	5	85	%	
VCC3 Power Supply Voltage	VCC3	-0.5	3.6	V	

Recommended Operating Condition

Parameter	Symbol	Min	Typical	Max	Unit
Operating Case Temperature	T _C	0		+70	°C
VCC3 Power Supply Voltage	VCC3	3.13	3.3	3.47	V
VCC3 Power Supply Current	ICC3		-	1000	mA
Date Rate			9.95		Gbps
			2.488		Gbps
Date Rate Drift		-100		+100	PPM
Power Consumption	P			3	W

Transmitter Optical Characteristics

Parameter	Symbol	Min	Typical	Max	Unit	Notes
Optical Center Wavelength	λ	1575		1580	nm	



Optical Spectrum Width (-20dB)	$\Delta\lambda$	-	-	1	nm	
Side Mode Suppression Ratio	SMSR	30			dB	
Optical Waveform Diagram	Compliant with ITU G.987.2					Figure 1, Mask Margin>10%
Average Launch Optical Power (BOL)	AOP2	+4.5	-	+8	dBm	Launched into SMF
Average Launch Optical Power (EOL)		+4		+8	dBm	
Power-OFF Transmitter Optical Power				-39	dBm	Launched into SMF
Extinction Ratio	ER	8.2			dB	PRBS2 ³¹ -1 @9.95Gbps
Total Jitter	TJ			0.39	UI	PRBS2 ³¹ -1 @9.95Gbps
RIN ₁₅ OMA				-128	dB/Hz	
Transmitter Reflectance				-10	dB	
Transmitter and Dispersion Penalty	TDP			1	dB	Transmit on 20km SMF

Transmitter Electrical Characteristics

Parameter	Symbol	Min	Typical	Max	Unit	Notes
Data Input Differential Swing		120		850	mV	
Input Differential Impedance		90	100	110	Ω	
Transmitter Enable Voltage - Low		0		0.8	V	
Transmitter Disable Voltage - High		2.0		V _{CC}	V	

Transmitter Eye Mask Definitions and Test Procedure

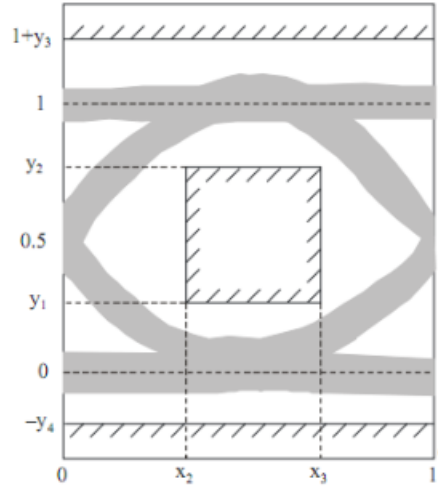

Figure 1: XGPON Transmitter Eye Mask Definitions

X3-X2	Y1	Y2	Y3	Y4	Unit
0.2	0.25	0.75	0.25	0.25	UI

10G PON Receiver Optical Characteristics

Parameter	Symbol	Min	Typical	Max	Unit	Notes
Operating Wavelength		1260		1280	nm	
Max Optical Input				0	dBm	Input without Incurring Damage
Sensitivity (BOL)				-29	dBm	PRBS 2 ³¹ -1 @9.95Gbps, BER ≤ 1 × 10 ⁻³
Sensitivity (EOL)	SEN			-28	dBm	PRBS 2 ³¹ -1 @9.95Gbps, BER ≤ 1 × 10 ⁻³
Saturation Optical Power	SAT	-9			dBm	PRBS 2 ³¹ -1 @9.95Gbps, BER ≤ 1 × 10 ⁻³
SD Assert Level				-30	dBm	



SD De-assert Level		-45			dBm	
Hysteresis		0.5		6	dB	
Receiver Reflectance				-12	dB	

2.5G PON Receiver Optical Characteristics

Parameter	Symbol	Min	Typical	Max	Unit	Notes
Operating Wavelength		1260		1280	nm	
Max Optical Input				0	dBm	Input without Incurring Damage
Sensitivity (BOL)				-30.5	dBm	PRBS 2 ²³ -1@2.488Gbps BER ≤ 1 × 10 ⁻⁴
Sensitivity (EOL)	SEN			-29.5	dBm	PRBS 2 ²³ -1@2.488Gbps BER ≤ 1 × 10 ⁻⁴
Saturation Optical Power	SAT	-9			dBm	PRBS 2 ²³ -1@2.488Gbps BER ≤ 1 × 10 ⁻⁴
SD Assert Level				-31	dBm	
SD De-assert Level		-45			dBm	
Hysteresis		0.5		6	dB	
Receiver Reflectance				-20	dB	

Timing Parameter Definitions in Burst Mode Sequence

Parameter	Symbol	Min	Typical	Max	Unit	Notes
RSSI Trigger-Low		0		0.8	V	
RSSI Trigger-High		2.0		V _{cc}	V	
Data Output Differential Swing		340		850	mV	CML output, DC coupled
Reset-Low		0		0.8	V	
Reset-High		2.0		V _{cc}	V	
SD Voltage-Low		0		0.4	V	
SD Voltage-High		2.4		V _{cc}	V	
Reset Width	A	TBD			ns	
Reset to Valid Data Delay	B	TBD			ns	

SD De-assert Time	C			TBD	ns	
SD Assert Time	D			TBD	ns	
Data Recovery Time				400	ns	PRBS 2 ²³ -1 @2.488Gbps
				400	ns	PRBS 2 ³¹ -1 @9.95Gbps

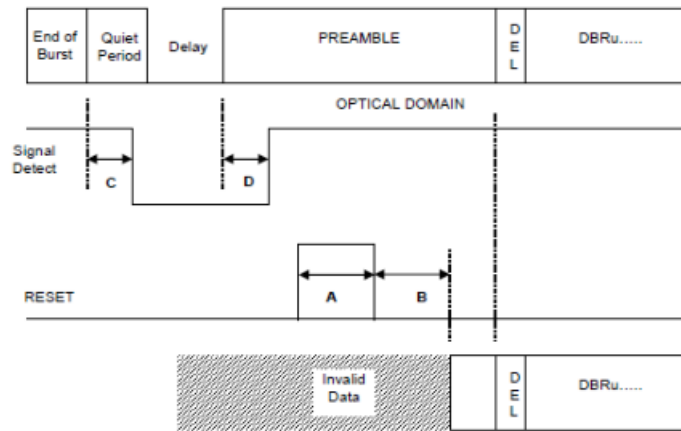

Figure 2: Reset Signal Timing Diagram in Normal Mode

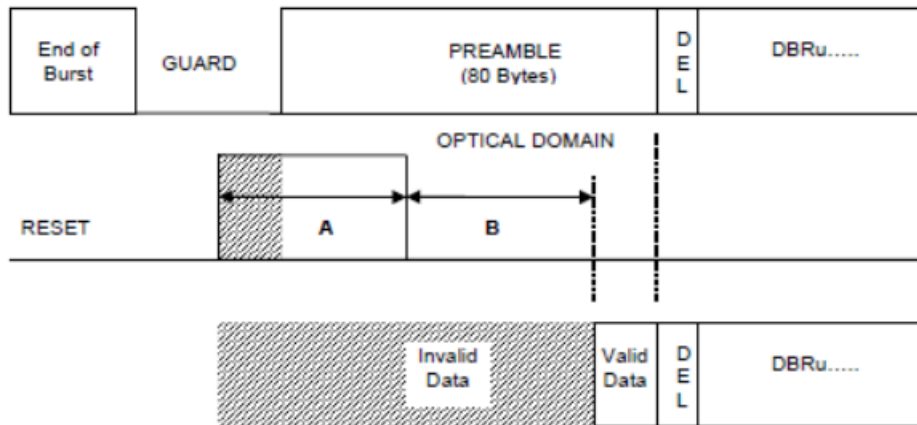

Figure 3: Reset Signal Timing Diagram in Ranging Mode

RSSI Timing Sequence

Parameter	Symbol	Min	Typical	Max	Unit	Notes
Optical Signal During Time	T_{ont}	1200			ns	
RSSI Trigger Width	T_w	500			ns	
RSSI Trigger Delay	T_D	150			ns	
I ² C Access Prohibited Time		500			μ s	

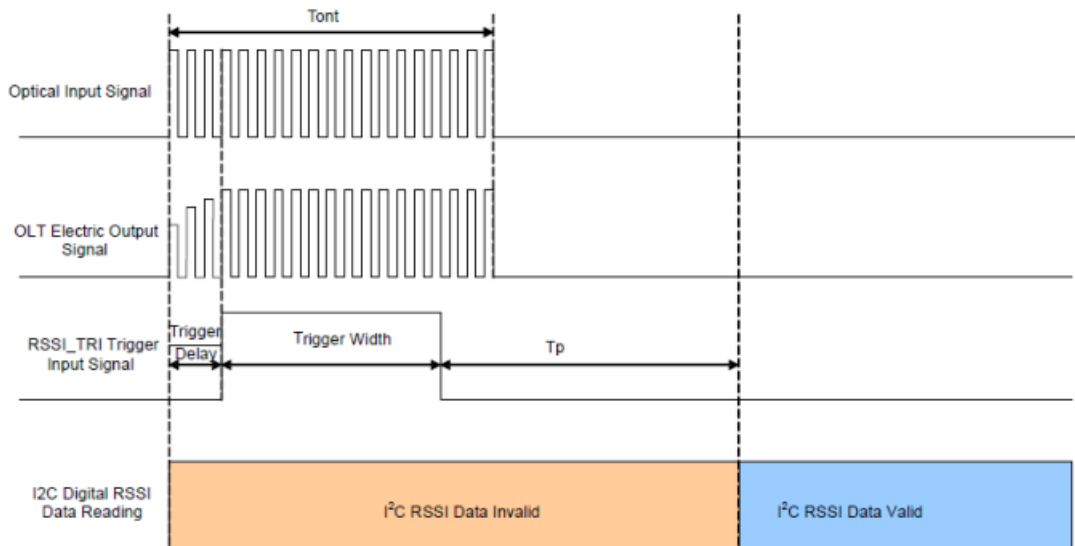

Figure 4: Timing Parameter Definitions in RSSI Trigger

Pin Out Drawing

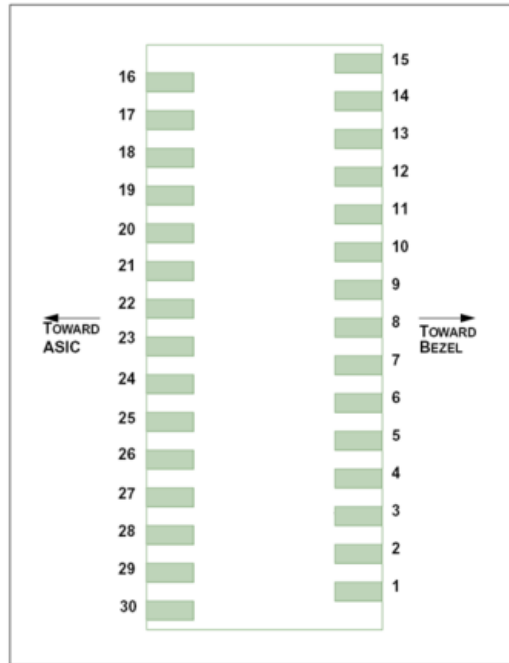

Figure 5: Pin out Drawing

Pin Description

PIN	Name	Description	Notes
1	GND	Module Ground	
2	TX_FAULT	Transmitter Status Indication	Low: Normal; High: Abnormal
3	NC	Not be Connected in the transceiver	
4	NC	Not be Connected in the transceiver	
5	TX_DIS	Transmitter Disable	LVTTTL Input by 10k pull up resistor, Low: transmitter on
6	VCC5	+5V Power Supply	
7	GND	Module Ground	
8	VCC3_TX	Transmitter 3.3V Power Supply	
9	VCC3_RX	Receiver 3.3V Power Supply	
10	SCL	The clock line	The clock line of two wire serial interface
11	SDA	The data line	The data line of two wire serial interface

12	MOD_ABS	Indicates Module is not present	Grounded in the Module
13	RX_Reset	Burst Receiver Reset	LVTTL, High level Reset
14	SD	SD Indication	LVTTL output. active LOW when the receiver lost signal
15	GND	Module Ground	
16	GND	Module Ground	
17	RD_N	Inverted Received Data Out	CML output, DC coupled; No squelch function
18	RD_P	Non-inverted Received Data Out	CML output, DC coupled; No squelch function
19	GND	Module Ground	
20	NC	Not be Connected in the transceiver	
21	RSSI_TRIG	RSSI Trigger for Transceiver	High value indicates start RSSI measurement
22	NC	Not be Connected in the transceiver	
23	GND	Module Ground	

24	NC	Not be Connected in the transceiver	
25	NC	Not be Connected in the transceiver	
26	GND	Module Ground	
27	GND	Module Ground	
28	TX_N	Inverted Transmit Data in	CML input, AC coupled
29	TX_P	Non-Inverted Transmit Data in	CML input, AC coupled
30	GND	Module Ground	

Typical Interface Circuit

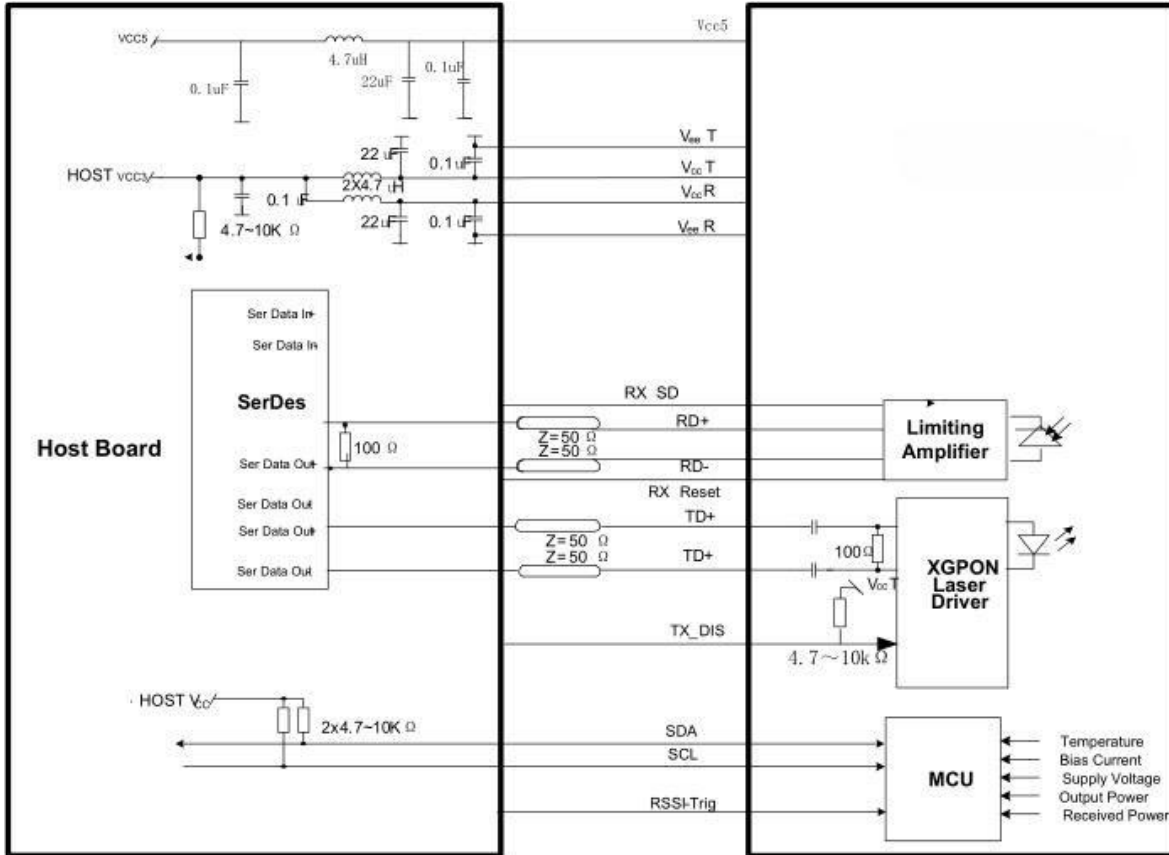

Figure 6: Typical Interface Circuit

EEPROM Information

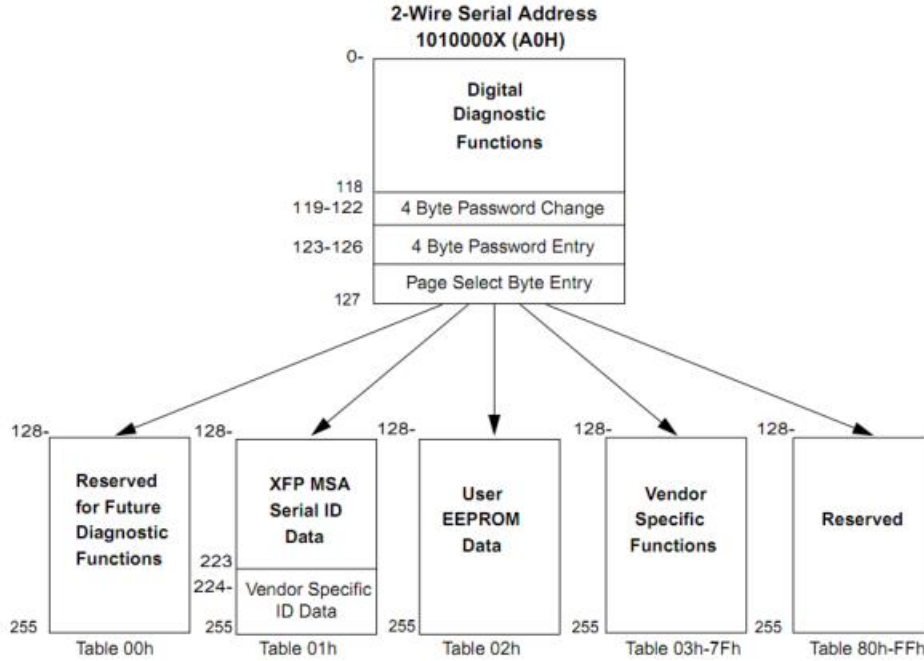

Figure 7: EEPROM Memory Map Specific Data Field Descriptions

Digital Diagnostic Monitoring Interface

Parameter	Range	Accuracy	Calibration	Notes
Temperature	0 to 70°C	±3°C	Internal	LSB: 1/256°C
Voltage	0 to 3.6 V	±5%	Internal	LSB: 0.1mV
Bias Current	0 to 262mA	±10%	Internal	LSB: 4uA
TX Power	2 to 10dBm	±2dB	Internal	LSB: 0.2uW
RX Power	-29 to -8dBm	±3dB	Internal	LSB: 0.1uW

Package Outline

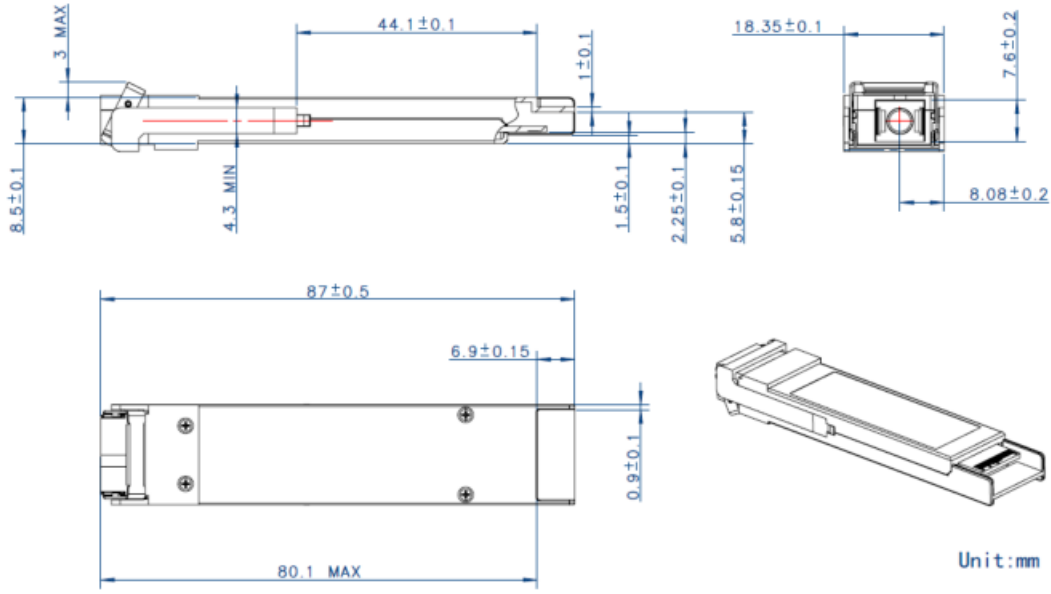

Figure 8: Package Outline

Ordering Information

Part Number	XGSPON-OLT-XN2
Application	XGSPON OLT ,0°C~+70°C
Wavelength (nm)	1577T/1270R
Data Rate (Gb/s)	9.95T/9.95R/2.5R
ODN Class	N2
Package	XFP
Connector	SC