



DO-LYxxL-V00

SFP28 25Gb/s CWDM 10km Transceiver

PRODUCT FEATURES

- Up to 25.78Gbps Data Links
- Up to 10km transmission on SMF
- CWDM DFB Laser and PIN receiver
- Metal enclosure, for lower EMI
- Hot-pluggable SFP28 footprint
- Specifications compliant with SFF 8472
- Build-in dual CDR with bypass function
- 25G/10G Auto-speed Switch
- Compliant with SFF-8402 with LC connector
- 2-wire interface with integrated Digital Diagnostic monitoring
- Single 3.3V power supply
- Power dissipation < 1.5W
- Case operating temperature :
 - Commercial: 0°C to +70°C
 - Extended: -10°C to +85°C

APPLICATIONS

- 25GBASE-LR
- eCPRI and CPRI



PRODUCT DESCRIPTION

DO-LYxxL-V00 Small Form Factor Pluggable (SFP) transceivers are compatible with the SFP28 Multi-Sourcing Agreement (MSA). The transceiver consists of four sections: the LD driver, the limiting amplifier, the CWDM DFB laser and the PIN photo-detector. The module data link up to 10KM in 9/125um single mode fiber.

The optical output can be disabled by a TTL logic high-level input of Tx Disable. Tx Fault is provided to indicate that degradation of the laser. Loss of signal (LOS) output is provided to indicate the loss of an input optical signal of receiver or the link status with partner.

Product selection

Wavelength	xx	Wavelength	xx
1271 nm	27	1331 nm	33
1291 nm	29	1351 nm	35
1311 nm	31	1371 nm	37

Absolute Maximum Ratings

Parameter	Symbol	Min.	Typ.	Max.	Unit	Note
Storage Temperature	T _s	-40	-	85	°C	
Relative Humidity(Non-condensing)	R _H	0	-	85	%	
Power Supply Voltage	V _{CC}	-0.3	-	4	V	
Signal Input Voltage	V _{SI}	V _{CC} -0.3	-	V _{CC} +0.3	V	

Recommended Operating Conditions

Parameter	Symbol	Min.	Typ.	Max.	Unit	Note
Case Operating Temperature	T _{case}	-10		85	°C	
		0		70	°C	
Power Supply Voltage	V _{CC}	3.14	3.3	3.47	V	
Power Supply Current	I _{CC}	-		450	mA	
Data Rate	BR		25.78		Gbps	TX Rate/RX Rate
Transmission Distance	TD		10		km	
Coupled fiber	Single mode fiber					9/125um SMF

Optical Characteristics

Parameter	Symbol	Min.	Typ.	Max.	Unit	Note
Transmitter						
Average Launched Power	P_o	0		+6.0	dBm	
Center Wavelength Range	λ_c	$\lambda - 6.5$	-	$\lambda + 6.5$	nm	Note(1)
Spectrum Bandwidth(-20dB)	$\Delta\lambda$	-	-	1	nm	
Side-Mode Suppression Ratio	SMSR	30	-	-	dB	
Extinction Ratio	ER	3.5		-	dB	Note (2)
Relative Intensity Noise	$RIN_{20\text{OMA}}$			-130	dB/Hz	
Average Launched Power(Laser Off)	P_{off}	-	-	-30		
Optical return loss tolerance				20	dB	
Transmitter reflectance				-12	dB	
Transmitter eye mask definition {X1, X2, X3, Y1, Y2, Y3} Hit ratio 5×10^{-5} hits per sample		{0.31, 0.4, 0.45, 0.34, 0.38, 0.4}				Note (3)
Receiver						
Input Optical Wavelength	λ_{IN}	1270	-	1610	nm	
Damage threshold		3			dBm	
Receiver Sensitivity	P_{sen1}	-	-	-13.3	dBm	Note (4)
Input Saturation Power (Overload)	P_{SAT}	2.0	-	-	dBm	Note (4)
Los Of Signal Assert	P_A	-30	-	-	dBm	
Los Of Signal De-assert	P_D	-	-	-15	dBm	
LOS -Hysteresis	P_{Hys}	0.5		6	dB	

Note:

Note (1): λ is: 1271~1371 (nm), please refer to 'product selection'

Note (2): Measured with a PRBS 231-1 test pattern, @25.78Gb/s.

Note (3): Transmitter eye mask definition, Compliant with IEEE 802.3cc.

Note (4): Measured with Light source 1310nm, ER=3.5dB; BER = $\leq 5 \times 10^{-5}$ @PRBS=231-1 NRZ.

Electrical Interface Characteristics

Parameter	Symbol	Min.	Typ.	Max.	Unit	Note
Transmitter						
Input differential impedance	R _{in}		100		Ω	1
Single ended data input swing	V _{in,pp}	180		700	mV	
Transmitter Fault Output-High	V _{FaultH}	2	-	V _{cc} +0.3	V	
Transmitter Fault Output-Low	V _{FaultL}	0	-	0.8	V	
Transmitter Disable Voltage- High	V _{DisH}	2	-	V _{cc} +0.3	V	
Transmitter Disable Voltage- low	V _{DisL}	0	-	0.8	V	
Receiver						
Differential data output swing	V _{out,pp}	300		850	mV	2
LOS Output Voltage-High	V _{LOSH}	2	-	V _{cc} +0.3	V	
LOS Output Voltage-Low	V _{LOSL}	0	-	0.8	V	

Notes:

1. Connected directly to TX data input pins. AC coupled thereafter.
2. Into 100 ohms differential termination.

Pin Description

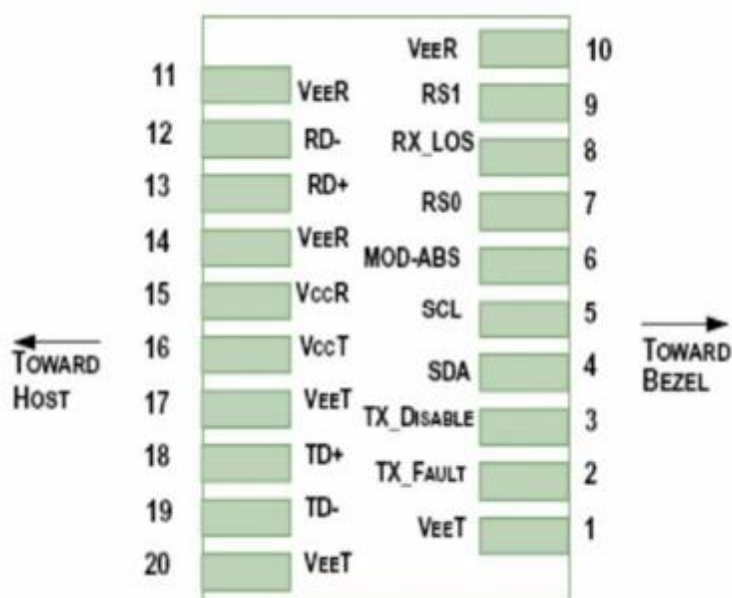

Diagram of Host Board Connector Block Pin Numbers and Name

Pin	Symbol	Name/Description	NOTE
1	V _{EE T}	Transmitter Ground (Common with Receiver Ground)	1

Pin	Symbol	Name/Description	NOTE
2	T _{FAULT}	Transmitter Fault.	2
3	T _{DIS}	Transmitter Disable. Laser output disabled on high or open.	3
4	SDA	2-wire Serial Interface Data Line	4
5	SCL	2-wire Serial Interface Clock Line	4
6	MOD_ABS	Module Absent. Grounded within the module	4
7	RS0	Rate Select 0, internal pull down	5
8	LOS	Loss of Signal indication. Logic 0 indicates normal operation.	6
9	RS1	Rate Select 1, internal pull down	5
10	V _{EER}	Receiver Ground (Common with Transmitter Ground)	1
11	V _{EER}	Receiver Ground (Common with Transmitter Ground)	1
12	RD-	Receiver Inverted DATA out. AC Coupled	
13	RD+	Receiver Non-inverted DATA out. AC Coupled	
14	V _{EER}	Receiver Ground (Common with Transmitter Ground)	1
15	V _{CCR}	Receiver Power Supply	
16	V _{CCT}	Transmitter Power Supply	
17	V _{EET}	Transmitter Ground (Common with Receiver Ground)	1
18	TD+	Transmitter Non-Inverted DATA in. AC Coupled.	
19	TD-	Transmitter Inverted DATA in. AC Coupled.	
20	V _{EET}	Transmitter Ground (Common with Receiver Ground)	1

Notes:

1. Circuit ground is internally isolated from chassis ground.
2. T_{FAULT} is an open collector/drain output, which should be pulled up with a 4.7k – 10k Ohms resistor on the host board if intended for use. Pull up voltage should be between 2.0V to V_{cc} + 0.3V. A high output indicates a transmitter fault caused by either the TX bias current or the TX output power exceeding the preset alarm thresholds. A low output indicates normal operation. In the low state, the output is pulled to <0.8V.
3. Laser output disabled on T_{DIS}>2.0V or open, enabled on T_{DIS}<0.8V.
4. Should be pulled up with 4.7kΩ- 10kΩ host board to a voltage between 2.0V and 3.6V. MOD_ABS pulls line low to indicate module is plugged in.
5. Internally pulled down per SFF-8431 Rev 4.1.
6. LOS is open collector output. It should be pulled up with 4.7kΩ – 10kΩ on host board to a voltage between 2.0V and 3.6V. Logic 0 indicates normal operation; logic 1 indicates loss of signal.

Block Diagram of Transceiver

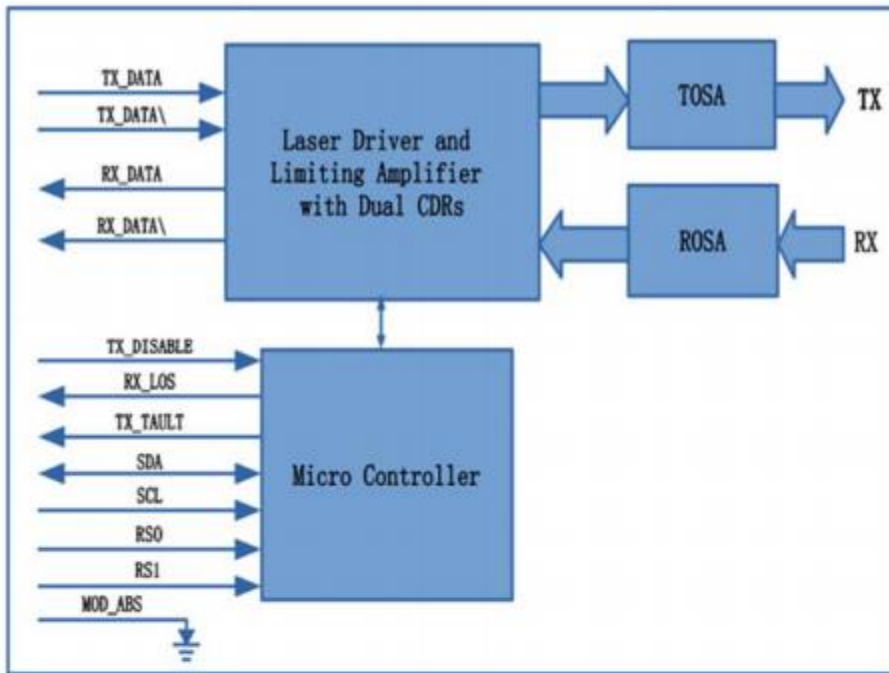

Recommended Interface Circuit

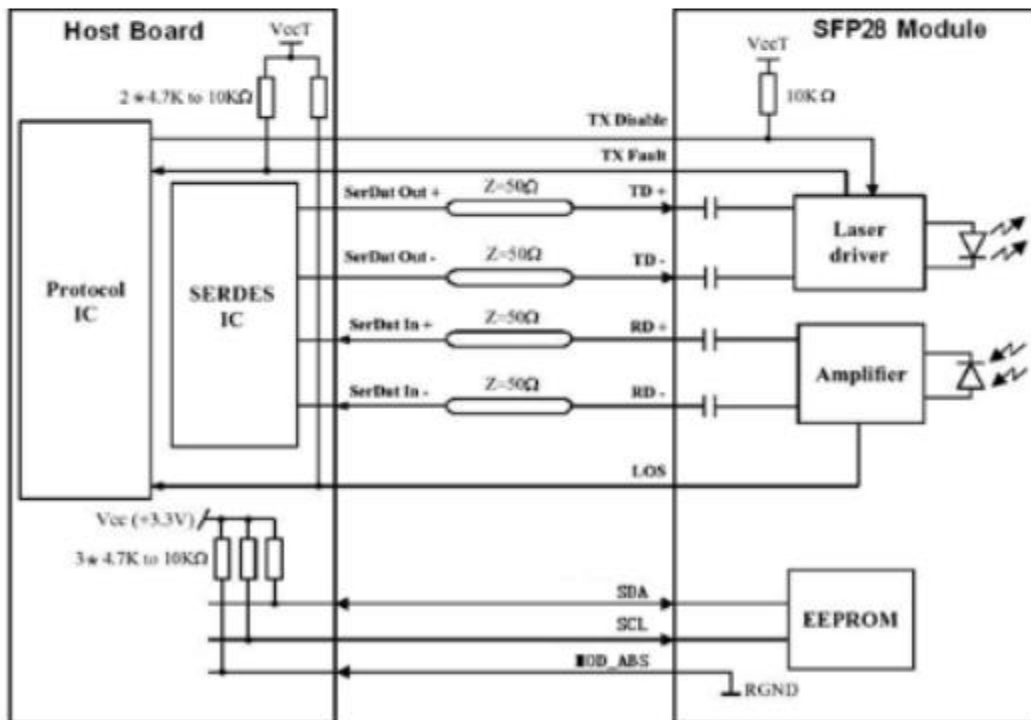

Outline Dimensions

