

XGSPON-OLT-SNx

XGSPON OLT T1577nm/R1270nm SFP+ N1/N2 Transceiver

Product Features

- ❖ 1577 nm Tx and 1270 nm Rx Bidirectional Transceiver
- ❖ Industry Leading Low Power Consumption
- ❖ Excellent EMI Immunity
- ❖ SC/UPC Optical Interface
- ❖ Transmitter Characteristics: 9.953 Gb/s Tx CW Mode Data Rate, 1577 nm CW Mode EML
- ❖ Receiver Characteristics: 9.953 Gb/s, 2.488 Gb/s Rx Burst Mode Data Rate, 1270 nm APD Receiver
- ❖ Case temperature range: -5 °C to 70 °C
- ❖ DDMI Support
- ❖ Digital RSSI
- ❖ RoHS Compliance

Applications

- ❖ Symmetric XGS-PON Access Networks
- ❖ Asymmetric XG-PON Access Networks
- ❖ FTTH
- ❖ FTTB

Standards

- ❖ Complies with SFP+ MSA (SFF-8431)
- ❖ Complies with SFF-8472

- ❖ Complies with FDA 21CFR1040.10
- ❖ Complies with IEC 60825-2 Class I laser safety
- ❖ RoHS-6 compliant

Absolute Maximum Rating

Parameter	Symbol	Min	Max	Unit	Notes
Storage Ambient Temperature	TSTG	-40	+85	°C	These are absolute maximum ratings. It will damage, if used beyond these limits.
Relative Humidity Storage	RHS	5	90	%	
Relative Humidity Operating	RHO	5	85	%	
Module Supply Voltage	V _{cc}	0	3.6	V	

Recommended Operating Condition

Parameter	Symbol	Min	Typical	Max	Unit	Note
Case Operating Temperature	T _{case}	-5	+25	+70	°C	Commercial
Module Supply Voltage	V _{cc}	3.13	3.3	3.47	V	
Module Supply Current	I _{cc}			600	mA	

Transmitter Optical Characteristics

Parameter	Symbol	Min	Typical	Max	Unit	Notes
Transmitter Type		CW Mode EML				
Transmitter Signal Rate		9.953			Gb/s	
Average Launch Power	P _{out}	2		5	dBm	N1
		4		7		N2

Average Launch Power Tx OFF	Poff			-45	dBm	
Tolerance to the Transmitter Incident Light Power	Tt	-15			dB	
Optical Center Wavelength	λ	1575	1577	1580	nm	
Spectral Width	$\Delta\lambda$			1	nm	
Side Mode Suppression Mode	SMSR	30			dB	
Extinction Ratio	ER	8.2			dB	
Eye Diagram	Compliant with ITU-T G.987.2, G.9807.1					

Transmitter Electrical Characteristics

Parameter	Symbol	Min	Typical	Max	Unit	Notes
Tx Differential Input Amplitude	VIN	150		1000	mV	
Tx Differential Input Impedence	ZIN		100		Ω	
Tx_DIS, High	VTDH	2.0		V _{cc}	V	TX disabled
Tx_DIS, Low	VTDL	0		0.8	V	TX enabled
Tx_Fault, High	VTFH	2.4		3.3	V	
Tx_Fault, Low	VTFL	0		0.4	V	

Receiver Optical Characteristics

Parameter	Symbol	Min	Typical	Max	Unit	Notes
Receiver Type		Burst Mode				
Optical Center Wavelength	λ	1260	1270	1280	nm	

Damage Optical Power	Pd	-5			dBm	
Receiver Sensitivity @9.953 Gb/s	PIN			-28.0	dBm	(*1)
Receiver Sensitivity @2.488 Gb/s				-27.5	dBm	N1 (*2)
				-29.5	dBm	N2 (*2)
Receiver Optical Overload	PIN(MAX)	-7			dBm	
Reflectance of Rx	ORL	-		-20	dB	@1260~1360 nm
Dynamic Range	DR	15			dB	
Reflected Optical Isolation	ROI	25			dB	From external 1575~1580 nm relative to 1260~1280 nm
SD Assert Power	SDA	-45		-30	dBm	
SD De-assert Power	SDD	-45		-30	dBm	
SD Hysteresis	Hy	0.5		5	dB	
Immunity from Continuous Identical Digits	CID	72			Bits	

(*1) 9.953 Gb/s: BER@1E-3PRBS $2^{31}-1$ ER=6.0 dB

(*2) 2.488 Gb/s: BER@1E-4 PRBS $2^{23}-1$ ER=8.2 dB

Receiver Electrical Characteristics

Parameter	Symbol	Min	Typical	Max	Unit	Condition/Notes
Rx Differential Output Impedence	Zout	90	100	110	Ω	
Rx_Data Differential Output Amplitude	Vout	300		1000	mV	CML
Rx_SD High State Logic (Normal)	VOH	2.4		Vcc	V	LVTTTL
Rx_SD Low State Logic (Fault)	VOL	0		0.4	V	LVTTTL

Pin Out Drawing

TOP VIEW
OF BOARD

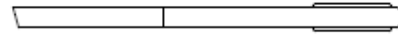
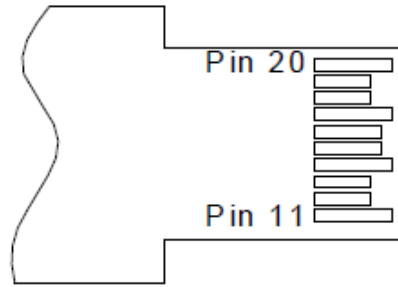

BOTTOM VIEW
OF BOARD

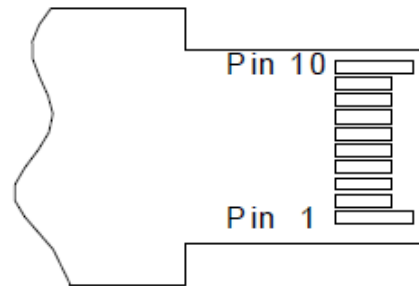

Figure 1. Pin-out Drawing

Pin Description

PIN	Name	Description	Notes
1	GND	Module Ground	
2	Tx_Fault	Transmitter Fault, LOW = Normal Operation, HIGH = Fault Indication	
3	Tx_DIS	Transmit Disable, LOW = Normal Operation, HIGH = Disable	
4	SDA	2-WireSerial Interface Data Line	
5	SCL	2-WireSerial Interface Clock	
6	Mod_Abs	Module Absent indicate pin, Grounded inside the module	
7	Reset	Set high level to reset RX.	
8	Rx_SD	High: signal detected, LOW: loss of signal	
9	TRI	Receiver Signal Strength Indication trigger input	

10	GND	Module Ground	
11	GND	Module Ground	
12	RD-	Receiver Inverted Rx Data Output, internally DC-coupled	
13	RD+	Receiver Non-Inverted Rx Data Output, Internally DC-coupled	
14	GND	Module Ground	
15	VCC3	+3.3 V DC Power Supply Input	
16	VCC3	+3.3 V DC Power Supply Input	
17	GND	Module Ground	
18	TD+	Transmitter Non-Inverted Data Input, internally AC-coupled	
19	TD-	Transmitter Inverted Data Input, internally AC-coupled	
20	GND	Module Ground	

Electrical Interface

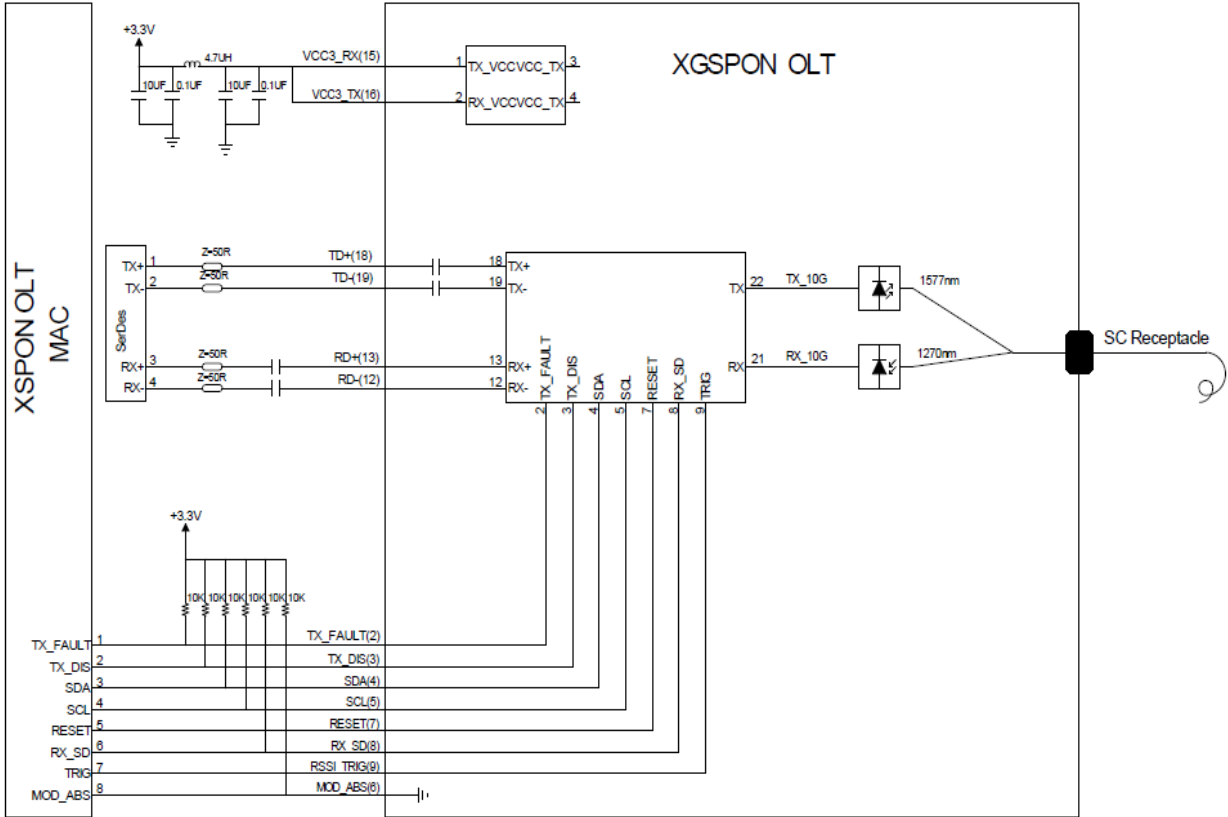

Figure 2. Electrical Interface

EEPROM Block Diagram

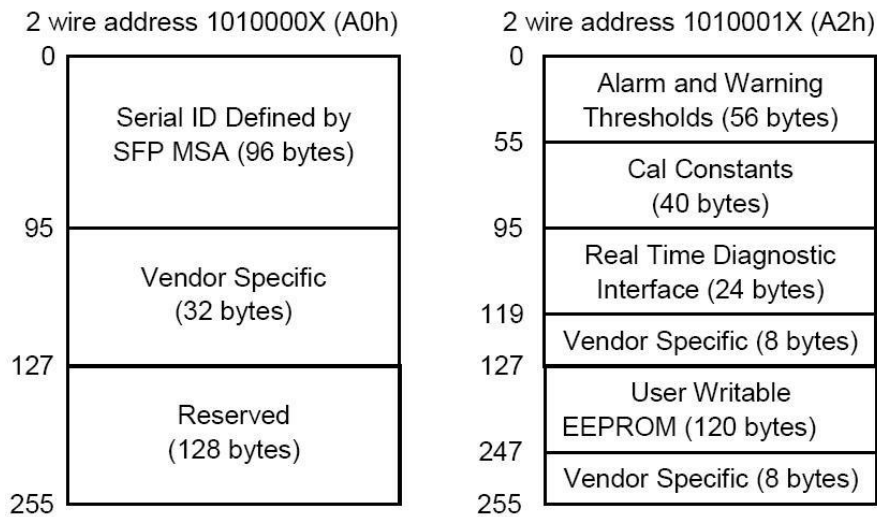

Figure 3. 2-Wire Serial Digital Memory Map

A/D Readout (Table A2H Byte 96~109)

Byte Address	Name	Description	Calibration	Precision	Unit
--------------	------	-------------	-------------	-----------	------

96-97	Temperature	Internally measured module temperature	Internal	±3	°C
98-99	Vcc3.3V	Internally measured the 3.3 V power	Internal	±3%	V
100-101	Bias Current	Internally measured Tx Bias Current, unit 4 uA	Internal	±10%	mA
102-103	Tx_Power	Internally measured 10 G Tx output power, unit 0.2 uW	Internal	±2	dB
104-105	Rx_Power	Internally measured Rx input power, unit 0.1 uW	External/Internal	±3	dB
106-107	Reserved				
108-109	Reserved				

Digital RSSI Sample/Hold Timing

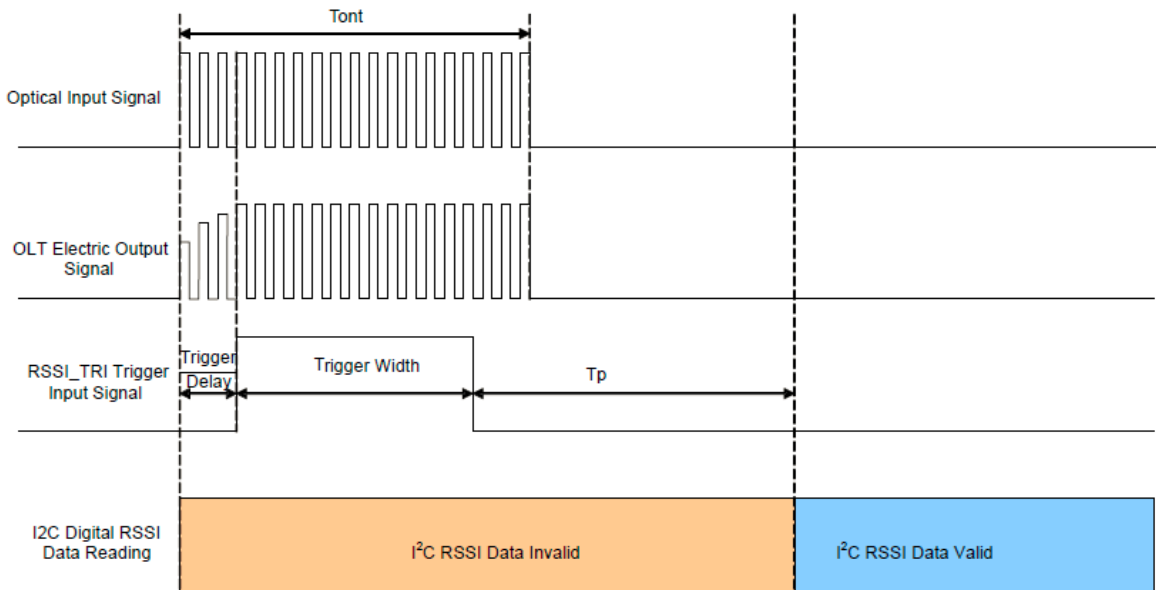

Figure 4. Digital RSSI Sample/Hold Timing

Digital RSSI Sample/Hold Timing

Parameter	Symbol	Min	Typical	Max	Unit	Notes
Optical Input Signal	Tont	300			ns	
RSSI Trigger Delay	Td(Trigger Delay)	25		3000	ns	

RSSI Trigger Width	Tw(Trigger Width)	500		Ttri+Ti2c	ns	
I2C Sample Period	Tp			150	us	
RSSI Monitor Range	Pmon	-30		-7	dBm	
RSSI Precision	Prssi	-2	+/-1	2	dB	
Ttri+Ti2c<Tont						

RX Burst Timing

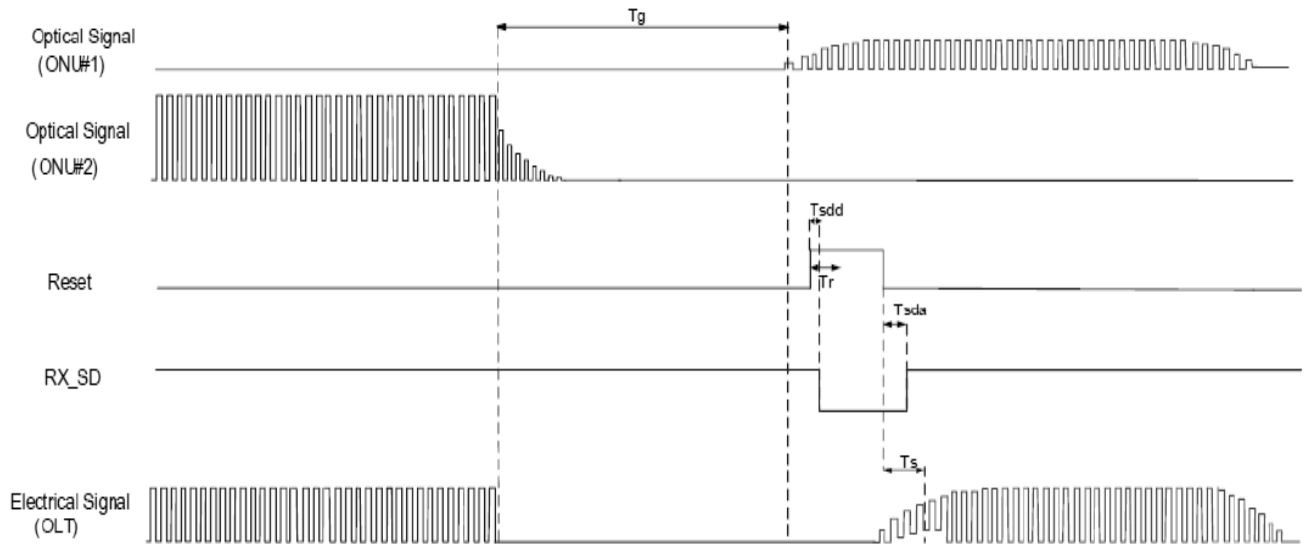

Figure 5. RX Burst Timing

RX Burst Timing

Parameter	Symbol	Min	Typical	Max	Unit	Notes
Guard Time	T_g	32	-	-	ns	
Reset Pulse Width	T_r	25.6			ns	
Receiver Threshold Settling Time	T_s		50	100	ns	

Burst Signal Detect Assert	TSDA	-	-	100	ns	
Burst Signal Detect De-Assert	TSDD	-	-	25.6	dBm	

Package Outline

unit:mm

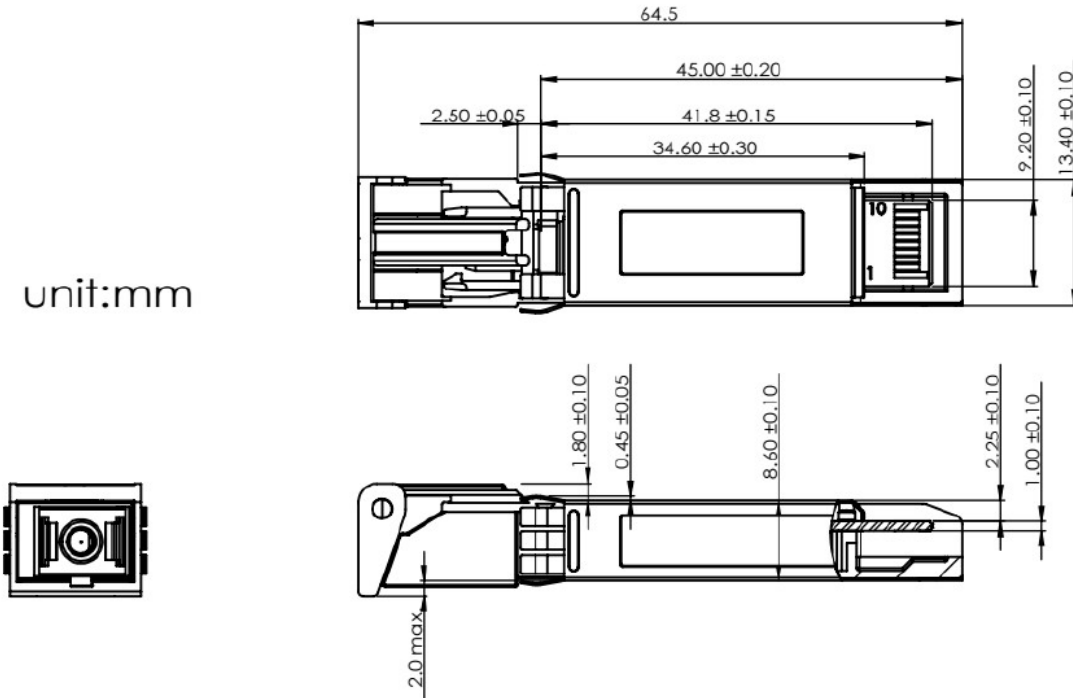

Ordering Information

Part Number	XGSPON-OLT-SN1/XGSPON-OLT-SN2
Application	XGSPON OLT, -5°C~+70°C
Wavelength (nm)	T1577/R1270
Data Rate (Gb/s)	T9.95/R9.95, 2.488
ODN Class	N1/N2



Package	SFP+
Connector	SC/UPC