

**10Gb/s SFP+ BiDi Optical Transceiver**  
**DC-9223C-20, 20Km SMF Application**  
**10GBASE-LR/LW Bi-directional, LC connector**

**Features**

- 10Gb/s serial optical interface compliant to 802.3ae 10GBASE-LR, single LC connector for bi-directional application, over20km SMF
- Electrical interface compliant to SFF-8431 specifications
- 1270/1330nm DFB transmitter, PIN photo-detector, integrated WDM
- 2-wire interface for management specifications compliant with SFF 8472
- Part number (-40°C to 85°C):
  - TR-DX12I-V00, 1270TX/1330RX
  - TR-DX33I-V00, 1330TX/1270RX
- Line side, client side loopback function;
- Advanced firmware allow customer system encryption information to be stored in transceiver
- ROHS compliant



**Applications**

- High speed storage area networks
- Computer cluster cross-connect
- Custom high-speed data pipes

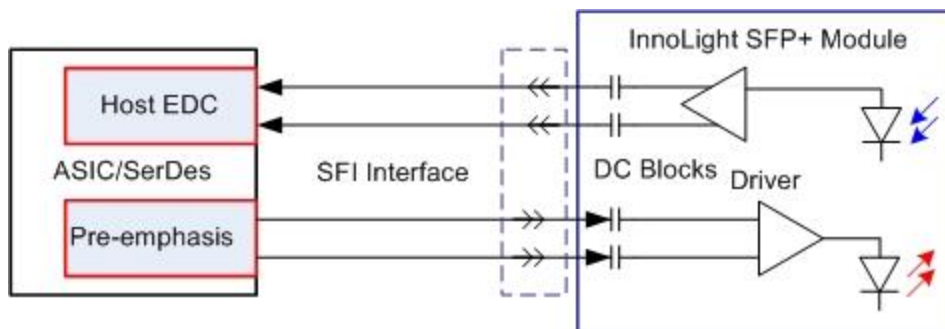

**Figure1: Application in System**

## 1. GENERAL DESCRIPTION

This 10Gigabit SFP+ BiDi transceiver is designed to transmit and receive optical data over single mode optical fiber for link length 20km.

The SFP+ BiDi module electrical interface is compliant to SFI electrical specifications. The transmitter input and receiver output impedance is 100 Ohms differential. Data lines are internally AC coupled. The module provides differential termination and reduce differential to common mode conversion for quality signal termination and low EMI. SFI typically operates over 200 mm of improved FR4 material or up to about 150mm of standard FR4 with one connector.

The transmitter converts 10Gbit/s serial PECL or CML electrical data into serial optical data compliant with the 10GBASE-LR standard. An open collector compatible Transmit Disable (Tx\_Dis) is provided. Logic "1" or no connection on this pin will disable the laser from transmitting. Logic "0" on this pin provides normal operation. The transmitter has an internal automatic power control loop (APC) to ensure constant optical power output across supply voltage and temperature variations. An open collector compatible Transmit Fault (Tx\_Fault) is provided. TX\_Fault is module output contact that when high, indicates that the module transmitter has detected a fault condition related to laser operation or safety. The TX\_Fault output contact is an open drain/collector and shall be pulled up to the Vcc\_Host in the host with a resistor in the range 4.7-10 kΩ. TX\_Disable is a module input contact. When TX\_Disable is asserted high or left open, the SFP+ module transmitter output shall be turned off. This contact shall be pulled up to VccT with a 4.7 kΩ to 10 kΩ resistor

The receiver converts 10Gbit/s serial optical data into serial PECL/CML electrical data. An open collector compatible Loss of Signal is provided. Rx\_LOS when high indicates an optical signal level below that specified in the relevant standard. The Rx\_LOS contact is an open drain/collector output and shall be pulled up to Vcc\_Host in the host with a resistor in the range 4.7-10 kΩ, or with an active termination. Power supply filtering is recommended for both the transmitter and receiver. The Rx\_LOS signal is intended as a preliminary indication to the system in which the SFP+ is installed that the received signal strength is below the specified range. Such an indication typically points to non-installed cables, broken cables, or a disabled, failing or a powered off transmitter at the far end of the cable.

## 2. PROPOSED APPLICATION SCHEMATICS

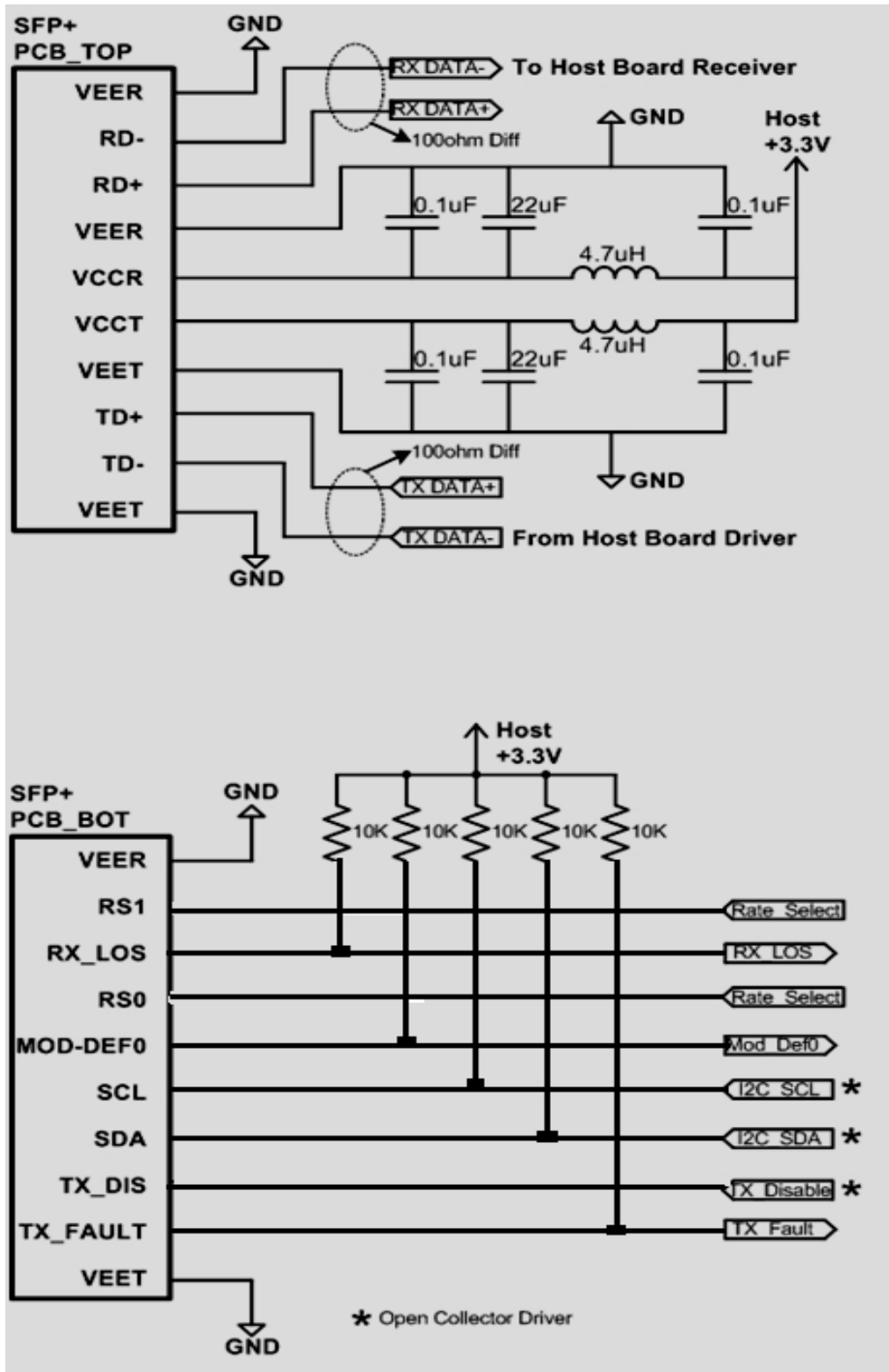

### 3. PIN DEFINITION

The SFP+ modules are hot-pluggable. Hot pluggable refers to plugging in or unplugging a module while the host board is powered. The SFP+ host connector is a 0.8 mm pitch 20 position right angle improved connector specified by SFF-8083, or stacked connector with equivalent with equivalent electrical performance. Host PCB contact assignment is shown in Figure 3 and contact definitions are given in Table 2. SFP+ module contacts mates with the host in the order of ground, power, followed by signal as illustrated by Figure 4 and the contact sequence order listed in Table 2.

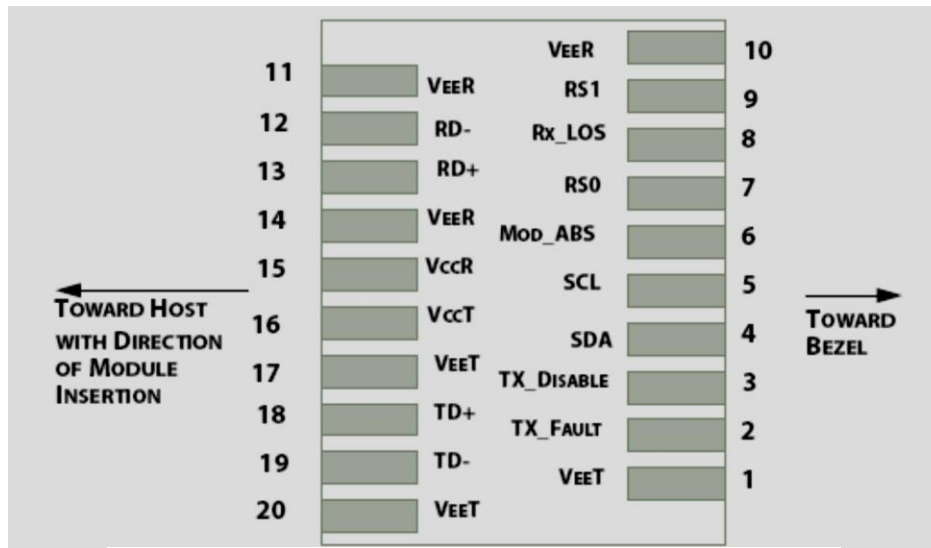

Figure 3: Module Interface to Host

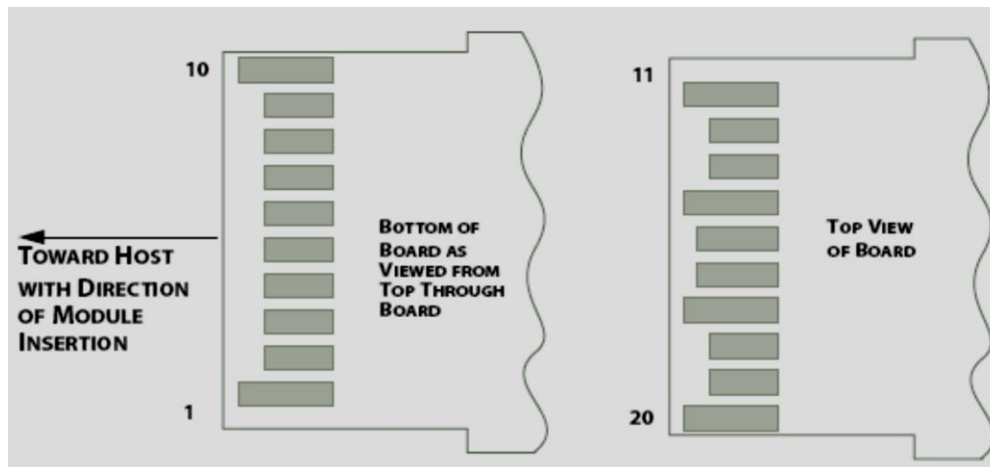
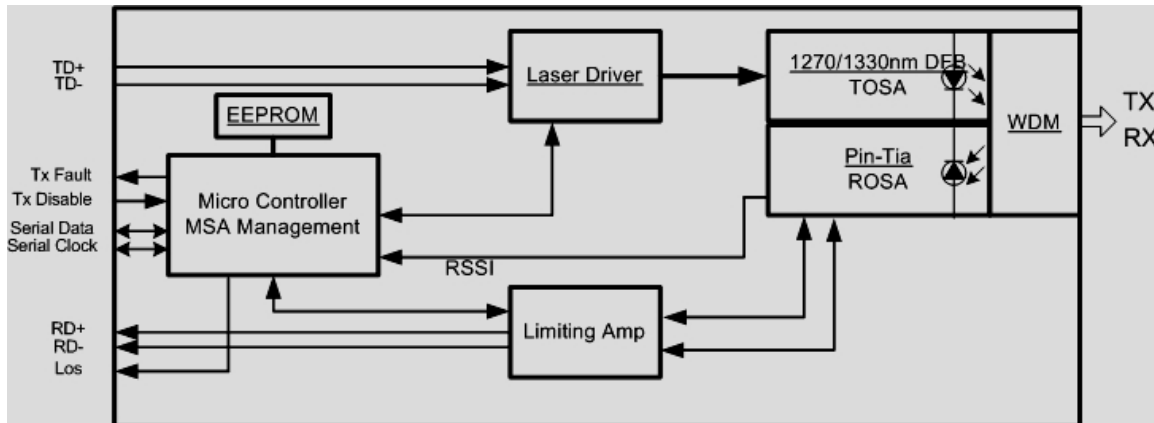

Figure 4: Module Contact Assignment



#### 4. TRANSCEIVER BLOCK DIAGRAM



#### 5. ABSOLUTE MAXIMUM RATING

These values represent the damage threshold of the module. Stress in excess of any of the individual Absolute Maximum Ratings can cause immediate catastrophic damage to the module even if all other parameters are within Recommended Operating Conditions.

Parameters	Symbol	Min.	Max.	Unit
Power Supply Voltage	V <sub>CC</sub>	0	3.6	V
Storage Temperature	T <sub>c</sub>	-40	85	°C
Operating Case Temperature	T <sub>c</sub>	-40	85	°C
Relative Humidity	RH	5	95	%
RX Input Average Power	P <sub>max</sub>	-	1.5	dBm

Table 2: Absolute Maximum Rating

#### 6. RECOMMENDED OPERATING ENVIRONMENT

Recommended Operating Environment specifies parameters for which the electrical and optical characteristics hold unless otherwise noted.

Parameters	Symbol	Min.	Typical	Max	Unit
Power Supply Voltage	V <sub>CC</sub>	3.135	3.3	3.465	V
Power Supply Current	I <sub>CC</sub>			300	mA
Operating Case Temperature, V00	T <sub>C-V</sub>	-40	25	85	°C

Table 3: Recommended Operating Environment

**7. OPTICAL CHARACTERISTICS**

The following optical characteristics are defined over the Recommended Operating Environment unless otherwise specified.

Parameter	Symbol	Min.	Typical	Max	Unit	Note
Operating Reach				20	km	
<b>Transmitter</b>						
Center wavelength TR-DX12I-V00	$\lambda$	1265		1275	nm	
TR-DX33I-V00		1325		1335	nm	
Side Mode Suppression Ratio	SMSR	30			dB	
Launched power	Po	-4.4		0.5	dBm	
Transmitter and dispersion penalty	DP			3.2	dB	
Average launch power of OFF transmitter	Poff			-30	dBm	
Extinction ratio	ER	3.5			dB	
RIN	RIN			-128	dB/Hz	
Optical Return Loss Tolerance	RL	12			dB	
<b>Receiver</b>						
Center wavelength TR-DX12I-V00	$\lambda$	1325		1335		
TR-DX33I-V00		1265	-	1275	nm	
Receiver Overload		0.5			dBm	1
Receiver Sensitivity	RSEN			-14.4	dBm	1

Receiver Reflectance	Rf			-12	dB	
Vertical eye closure penalty				2.2	dB	3
LOS Assert	LOSA	-30			dBm	
LOS De-assert	LOSD			-14.5	dBm	
LOS Hysteresis		0.5			dB	
Stressed eye jitter		0.3			UI	2
Receive electrical 3dB upper cutoff frequency				12.3	GHz	
Receiver power (damage)				1.5	dBm	

**Table 4: Optical Characteristics**

**Notes:**

1. Average optical power shall be measured using the methods specified in TIA/EIA-455-95.
2. Receiver sensitivity is informative. Stressed receiver sensitivity shall be measured with conformance test signal for BER =  $1 \times 10^{-12}$ .
3. Vertical eye closure penalty and stressed eye jitter are the test conditions for measuring stressed receiver sensitivity. They are not the required characteristic of the receiver.
4. Power budget is defined as the different between the Rx sensitivity and the Tx output power of the interface.
5. Path penalty is intended as the power penalty of the interface between back-to-back and the maximum applied dispersion.



**8. DIGITAL DIAGNOSTIC FUNCTIONS**

The following digital diagnostic characteristics are defined over the Recommended Operating Environment unless otherwise specified. It is compliant to SFF8472 Rev10.2 with internal calibration mode. For external calibration mode please contact our sales staff.

Parameter	Symbol	Min.	Max	Unit	Notes
Temperature monitor absolute error	DMI_Temp	-3	3	degC	Over operating temp
Laser power monitor absolute error	DMI_TX	-3	3	dB	
RX power monitor absolute error	DMI_RX	-3	3	dB	-1dBm to -15dBm range
Supply voltage monitor absolute error	DMI_VCC	-0.18	0.1	V	Full operating range
Bias current monitor	DMI_Ibias	-10%	10%	mA	

**Table5: Digital diagnostic specification table**

## 9. ELECTRICAL CHARACTERISTICS

The following electrical characteristics are defined over the Recommended Operating Environment unless otherwise specified.

Parameter	Symbol	Min.	Typical	Max	Unit	Notes
Data Rate		-	10.3125	-	Gbps	
Power Consumption		-	800	1000	mW	
<b>Transmitter</b>						
Single Ended Output Voltage Tolerance		-0.3	-	4	V	
C common mode voltage tolerance		15	-	-	mV	
Tx Input Diff Voltage	VI	180		700	mV	
Tx Fault	VoL	-0.3		0.4	V	At 0.7mA
Data Dependent Input Jitter	DDJ			0.1	UI	
Data Input Total Jitter	TJ			0.28	UI	
<b>Receiver</b>						
Single Ended Output Voltage Tolerance		-0.3	-	4	V	
Rx Output Diff Voltage	Vo	300		850	mV	
Rx Output Rise and Fall Time	Tr/Tf	30			ps	20% to 80%
Total Jitter	TJ			0.7	UI	
Deterministic Jitter	DJ			0.42	UI	

**Table 6: Electrical Characteristics**



## 11. MECHANICAL

Comply with SFF-8432 rev. 5.0, the improved Pluggable form factor specification.

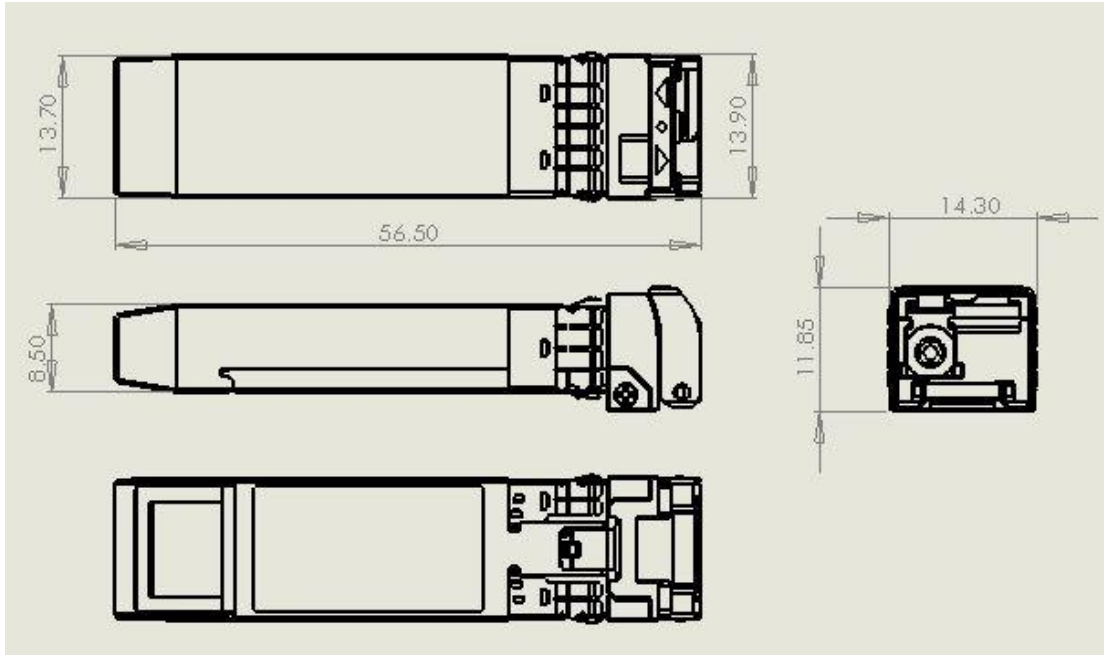

## 12. ESD

This transceiver is specified as ESD threshold 1kV for SFI pin and 2kV for all other electrical input pins, tested per MIL-STD-883, Method 3015.4 /JESD22-A114-A (HBM). However, normal ESD precautions are still required during the handling of this module. This transceiver is shipped in ESD protective packaging. It should be removed from the packaging and handled only in an ESD protected environment.

## 13. LASER SAFTY

This is a Class 1 Laser Product according to IEC 60825-1:2007. This product complies with 21 CFR 1040.10 and 1040.11 except for deviations pursuant to Laser Notice No. 50, dated (June 24, 2007)