

## DC-C2100-40

Single-Mode OTU4 4L1-9C1F CFP2 Transceiver  
Single-Mode 100GBASE-ER4 CFP2 Transceiver  
RoHS6 Compliant

### Features

- ◆ Supports 103Gbps and 112Gbps aggregate bit rates
- ◆ Single 3.3V Power Supply and Power dissipation < 9W
- ◆ Up to 40km transmission on SMF
- ◆ Hot-Pluggable CFP2 Footprint Duplex LC Connector Interface
- ◆ Class 1 FDA and IEC60825-1 Laser Safety Compliant
- ◆ RoHS6 Compliant
- ◆ Operating Case Temperature Standard: 0°C ~ +70°C
- ◆ Compliant with CFP2 MSA Specification
- ◆ MDIO interface with integrated Digital Diagnostic Monitoring
- ◆ 4 x 28G electrical interface



### Applications

- ◆ 100GBASE-ER4 Ethernet
- ◆ OTU4 4L1-9C1F

### Ordering Information

Part No.	Data Rate	Fiber	Distance* (Note2)	Interface	Temp.	DDMI
DC-C2100-40	112Gbps	SMF	40km	LC	Standard	Yes

Note: 40 km with 9/125µm SMF

## Absolute Maximum Ratings\*note4

Parameter	Symbol	Min.	Max.	Unit
Storage Temperature	T <sub>s</sub>	-40	+85	°C
Case Temperature	T <sub>c</sub>	-5	+75	°C
Supply Voltage	V <sub>cc</sub>	-0.5	3.6	V
Relative Humidity(Non-condensing)	RH	5	95	%

Note4: Exceeding any one of these values may destroy the device immediately.

## Recommended Operating Conditions

Parameter	Symbol		Min.	Typical	Max.	Unit
Operating Case Temperature	T <sub>c</sub>	EOLC-161HG-C-40-L1A	0		+70	°C
Operating Relative Humidity	RH		5		85	%
Power Supply Voltage	V <sub>cc</sub>		3.2	3.3	3.4	V
Power Consumption	P				9	W

## Performance Specifications - Electrical

Parameter	Symbol	Min.	Typ.	Max	Unit	Notes
<b>Transmitter</b>						
Input Amplitude (Differential)	V <sub>in</sub>			1050	mVpp	AC coupled inputs*(Note7)
Input Impedance (Differential)	Z <sub>in</sub>	80	100	120	ohms	R <sub>in</sub> > 100 kohms @ DC
<b>Receiver</b>						
Output Amplitude (Differential)	V <sub>out</sub>	360		770	mVpp	AC coupled outputs*(Note7)
Output Impedance (Differential)	Z <sub>out</sub>	80	100	120	ohms	
Output Rise/Fall Time	t <sub>r</sub> /t <sub>f</sub>	24			ps	20%~80%

## 1.2V MDIO Interface Specifications

Parameter	Symbol	Min.	Typ.	Max	Unit	Notes
Input Voltage	$V_{IH}$	0.84		1.5	V	
	$V_{IL}$	-0.3		0.36	V	
Input Leak current	$I_{IN}$	-100		100	$\mu A$	
Output Voltage	$V_{OH}$	1.0		1.5	V	
	$V_{OL}$	-0.3		0.2	V	
Input Capacitance	$C_I$			10	pF	
Input MDC Clock	$f_{MDC}$	0.1		4	MHz	
MDC Clock Period	$T_{MDC}$	250		10000	ns	
MDIO Hold Time	$T_{hold}$	10			ns	
MDIO SetupTime	$T_{setup}$	10			ns	
GLB_ALM	$T_{glb\_alm\_ass}$			150	ms	
	$T_{glb\_alm\_dea}$			150	ms	

## Optical and Electrical Characteristics

### OTU4 4L1-9C1F Operation

Parameter	Symbol	Min.	Typical	Max.	Unit
<b>Transmitter</b>					
Signaling Speed per Lane	$BR_{AVE}$		27.95		Gbps
Data Rate Variation		-20		+20	ppm
Lane_0 Center Wavelength	$\lambda_{C0}$	1294.53	1295.56	1296.59	nm
Lane_1 Center Wavelength	$\lambda_{C1}$	1299.02	1300.05	1301.09	nm
Lane_2 Center Wavelength	$\lambda_{C2}$	1303.54	1304.58	1305.63	nm
Lane_3 Center Wavelength	$\lambda_{C3}$	1308.09	1309.14	1310.19	nm
Total Average Output Power <sup>*(Note5)</sup>	$P_o$			8.9	dBm
Average Launch Power per Lane	$P_{each}$	-2.7		2.9	dBm
Maximum channel power difference				3.6	dB
Side Mode Suppression Ratio	SMSR	30			dB
Launch power of OFF Transmitter per lane				-30	dBm
Optical Return Loss Tolerance				20	dB
Extinction Ratio <sup>*(Note6)</sup>	ER	8			dB
Transmitter eye mask definition {X1, X2, X3, Y1, Y2, Y3} <sup>*(Note6)</sup>			G.959.1 Compliant		
TX Disable Assert Time	$t_{off}$			100	us
<b>Receiver</b>					
Signaling Speed per Lane	$BR_{AVE}$		27.95		Gbps
Data Rate Variation		-20		+20	ppm

Lane_0 Center Wavelength	$\lambda_{C0}$	1294.53	1295.56	1296.59	nm
Lane_1 Center Wavelength	$\lambda_{C1}$	1299.02	1300.05	1301.09	nm
Lane_2 Center Wavelength	$\lambda_{C2}$	1303.54	1304.58	1305.63	nm

Lane_3 Center Wavelength	$\lambda_{C3}$	1308.09	1309.14	1310.19	nm
Average Receive Power per Lane	Rpow	-20.7		4.5	dBm
Equivalent Receive Sensitivity per Lane*(Note8)	Pmin			-23.2	dBm
Damage threshold	Rdam	5.5			dBm
Maximum channel power difference				4.5	dB
Maximum Mean total input power				10.5	dBm
Maximum optical path penalty				2.5	dB
Optical Return Loss	ORL			-26	dB
LOS Assert	LOSA	-35		-26	dBm
LOS De-Assert	LOSD			-25	dBm
LOS Hysteresis		0.5			dB

## 100GBASE-ER4 Operation

Parameter	Symbol	Min.	Typical	Max.	Unit
<b>Transmitter</b>					
Signaling Speed per Lane	BR <sub>AVE</sub>		25.78		Gbps
Data Rate Variation		-100		+100	ppm
Lane_0 Center Wavelength	$\lambda_{C0}$	1294.53	1295.56	1296.59	nm
Lane_1 Center Wavelength	$\lambda_{C1}$	1299.02	1300.05	1301.09	nm
Lane_2 Center Wavelength	$\lambda_{C2}$	1303.54	1304.58	1305.63	nm
Lane_3 Center Wavelength	$\lambda_{C3}$	1308.09	1309.14	1310.19	nm
Total Average Output Power*(Note5)	P <sub>o</sub>			8.9	dBm
Average Launch Power per Lane*(Note5)	P <sub>each</sub>	-2.9		2.9	dBm
Difference in launch power between any two lanes(OMA)				3.6	dB
Side Mode Suppression Ratio	SMSR	30			dB
Average launch power of OFF transmitter per lane				-30	dBm
Optical Return Loss Tolerance				20	dB
Transmitter reflectance				-12	dB
Extinction Ratio*(Note11)	ER	8			dB
Transmitter eye mask definition *(Note11)		IEEE802.3ba-2010 Compliant			
TX Disable Assert Time	t <sub>off</sub>			100	us
<b>Receiver</b>					
Signaling Speed per Lane	BR <sub>AVE</sub>		25.78		Gbps
Data Rate Variation		-100		+100	ppm
Lane_0 Center Wavelength	$\lambda_{C0}$	1294.53	1295.56	1296.59	nm

Lane_1 Center Wavelength	$\lambda_{C1}$	1299.02	1300.05	1301.09	nm
Lane_2 Center Wavelength	$\lambda_{C2}$	1303.54	1304.58	1305.63	nm
Lane_3 Center Wavelength	$\lambda_{C3}$	1308.09	1309.14	1310.19	nm

Average Receive Power per Lane	Rpow	-20.9		4.5	dBm
Difference in receive power between any two lanes(OMA)				4.5	dB
Receive Sensitivity in OMA per Lane*(Note8)	Pmin			-21.4	dBm
Stressed Sensitivity(OMA) per lane	SRS			-17.9	dBm
Damage threshold per lane	Rdam	5.5			dBm
Optical Return Loss*(Note12)	ORL			-26	dB
LOS Assert	LOSA	-35		-26	dBm
LOS De-Assert	LOSD			-25	dBm
LOS Hysteresis*(Note10)		0.5			dB

Note5: Output is coupled into a 9/125µm single-mode fiber.

Note6: Filtered, measured with a PRBS 2<sup>31</sup>-1 test pattern @27.95Gbps

Note7: High speed I/O, internally AC coupled.

Note8: Minimum average optical power measured at BER less than 1E-12, with a 2<sup>31</sup>-1 PRBS.

Note9: Eye Pattern Mask

Note10: LOS Hysteresis

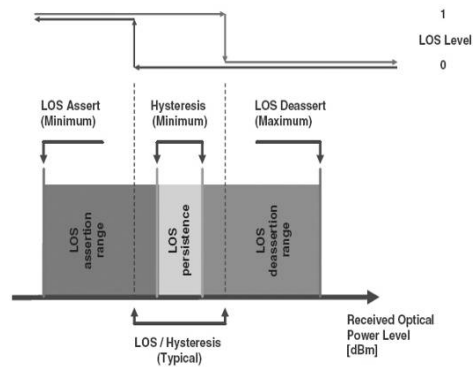
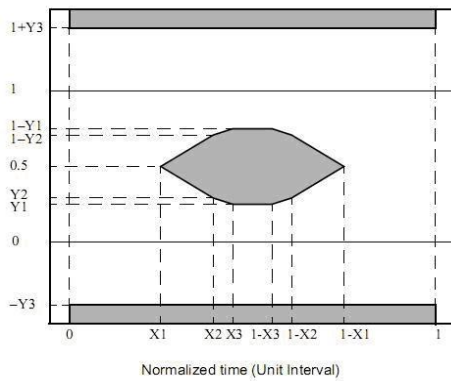

Note11: Filtered, measured with a PRBS 2<sup>31</sup>-1 test pattern @25.78Gbps

Note12: Conditions of stressed receiver sensitivity test at 1.8 dB vertical eye closure penalty per lane, 0.2 UI stressed eye J2 Jitter per lane, 0.47UI stressed eye J9 Jitter per lane.

Note13: Eye Margin within 1000 waveforms.

Note14: Measured at BER less than 1E-16 without FEC, average optical power.

## Functional Description of Transceiver

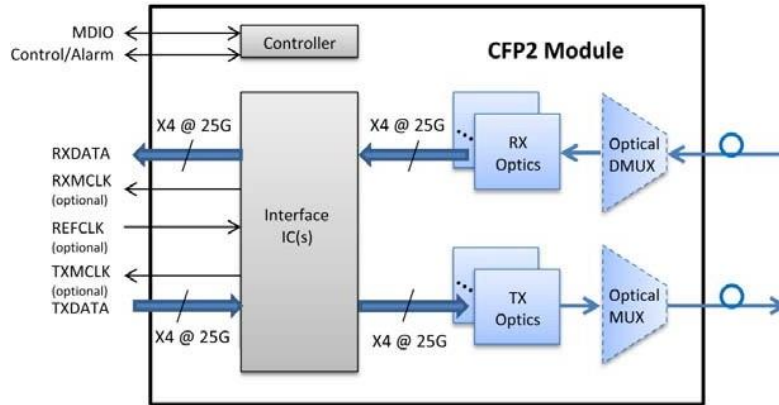

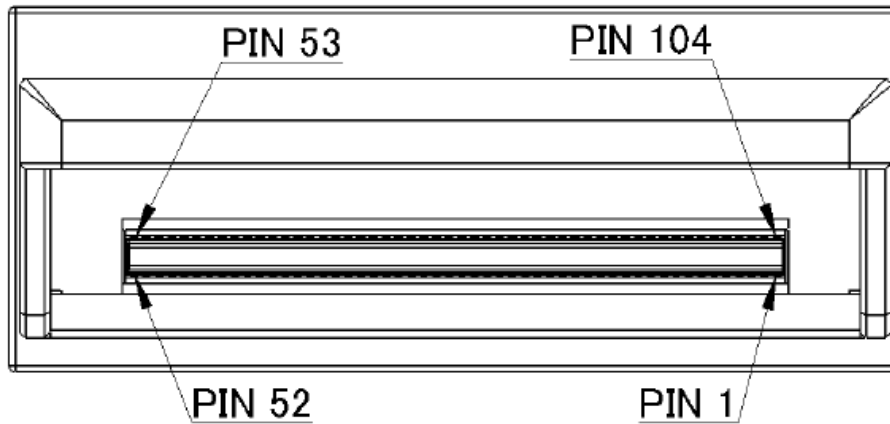

**CFP2 Transceiver Electrical Pad Layout****Pin Function Definitions**

CFP2	
Bottom	
1	GND
2	(TX_MCK_N)
3	(TX_MCK_P)
4	GND
5	N.C.
6	N.C.
7	3.3V_GND
8	3.3V_GND
9	3.3V
10	3.3V
11	3.3V
12	3.3V
13	3.3V_GND
14	3.3V_GND
15	VND_IO_A
16	VND_IO_B
17	PRG_CNTL1
18	PRG_CNTL2
19	PRG_CNTL3
20	PRG_ALARM1
21	PRG_ALARM2
22	PRG_ALARM3
23	GND
24	TX_DIS
25	RX_LOS
26	MOD_LOPWR
27	MOD_ABS

CFP2	
Top	
104	GND
103	N.C.
102	N.C.
101	GND
100	TX3n
99	TX3p
98	GND
97	TX2n
96	TX2p
95	GND
94	N.C.
93	N.C.
92	GND
91	N.C.
90	N.C.
89	GND
88	TX1n
87	TX1p
86	GND
85	TX0n
84	TX0p
83	GND
82	N.C.
81	N.C.
80	GND
79	(REFCLKn)
78	(REFCLKp)

28	MOD_RSTn
29	GLB_ALRMn
30	GND
31	MDC
32	MDIO
33	PRTADR0
34	PRTADR1
35	PRTADR2
36	VND_IO_C
37	VND_IO_D
38	VND_IO_E
39	3.3V_GND
40	3.3V_GND
41	3.3V
42	3.3V
43	3.3V
44	3.3V
45	3.3V_GND
46	3.3V_GND
47	N.C.
48	N.C.
49	GND
50	(RX_MCK_N)
51	(RX_MCK_P)
52	GND

77	GND
76	N.C.
75	N.C.
74	GND
73	RX3n
72	RX3p
71	GND
70	RX2n
69	RX2p
68	GND
67	N.C.
66	N.C.
65	GND
64	N.C.
63	N.C.
62	GND
61	RX1n
60	RX1p
59	GND
58	RX0n
57	RX0p
56	GND
55	N.C.
54	N.C.
53	GND

## Bottom Row Pin Descriptions

Pin Num.	Name	Function	Notes
1	GND		
2	(TX_MCK_N)	O CML	For optical waveform testing. Not for normal use.
3	(TX_MCK_P)	O CML	For optical waveform testing. Not for normal use.
4	GND		
5	N.C.		
6	N.C.		
7	3.3V_GND		
8	3.3V_GND		
9	3.3V		
10	3.3V		
11	3.3V		3.3V Module Supply Voltage



**do**  
networks

## CFP2 Series Preliminary

12	3.3V		
13	3.3V_GND		
14	3.3V_GND		

15	VND_IO_A		Module Vendor I/O A. Do not connect!
16	VND_IO_B		Module Vendor I/O B. Do not connect!
17	PRG_CNTL1		Programmable control 1 set over MDIO, MSA default: TRXIC_RSTn. TX&RX ICs reset. "0": reset; "1" or NC: enabled = not used.
18	PRG_CNTL2		Programmable Control 2 set over MDIO, MSA Default: Hardware Interlock LSB, "00": ≤3W, "01": ≤6W, "10": ≤9W, "11" or NC: ≤12W = not used
19	PRG_CNTL3		Programmable Control 3 set over MDIO, MSA Default: Hardware Interlock MSB, "00": ≤3W, "01": ≤6W, "10": ≤9W, "11" or NC: ≤12W = not used
20	PRG_ALRM1		Programmable alarm 1 set over MDIO, MSA default: HIPWR_ON. "1": module power Up completed; "0": module not high powered up.
21	PRG_ALRM2		Programmable alarm 2 set over MDIO, MSA default: MOD_READY. "1": ready; "0": not ready.
22	PRG_ALRM3		Programmable alarm 3 set over MDIO, MSA default: MOD_FAULT, fault detected. "1": fault; "0": not fault.
23	GND		
24	TX_DIS	I LVCMOS	Transmitter disable for all lanes. "1" or NC: transmitter disabled; "0": transmitter enabled.
25	RX_LOS	O LVCMOS	Receiver loss of optical signal. "1": low optical signal; "0": normal condition.
26	MOD_LOPWR	I LVCMOS	Module Low power mode. "1" or NC: module in low power (safe) mode; "0": power-on enabled.
27	MOD_ABS	O GND	Module Absent. "1" or NC: module absent; "0": module present. Pull up resistor on Host.
28	MOD_RSTn	I LVCMOS	Module Reset. "0": resets the module; "1" or NC: module enabled. Pull Down Resistor in module.
29	GLB_ALRMn	O LVCMOS	Global Alarm. "0": alarm condition in any MDIO alarm register; "1": no alarm condition. Open Drain, Pull up resistor on Host
30	GND		
31	MDC	I 1.2V CMOS	Management Data Clock
32	MDIO	I/O 1.2V CMOS	Management Data I/O bi-directional data
33	PRTADR0	I 1.2V CMOS	MDIO Physical Port address bit 0
34	PRTADR1	I 1.2V CMOS	MDIO Physical Port address bit 1
35	PRTADR2	I 1.2V CMOS	MDIO Physical Port address bit 2
36	VND_IO_C	I/O	Module Vendor I/O C. Do not connect!
37	VND_IO_D	I/O	Module Vendor I/O D. Do not connect!
38	VND_IO_E	I/O	Module Vendor I/O E. Do not connect!

39	3.3V_GND		
40	3.3V_GND		
41	3.3V		3.3V Module Supply Voltage

42	3.3V			
43	3.3V			
44	3.3V			
45	3.3V_GND			
46	3.3V_GND			
47	N.C.			No Connect
48	N.C.			No Connect
49	GND			
50	(RX_MCK_N)	O	CML	For optical waveform testing. Not for normal use.
51	(RX_MCK_P)	O	CML	For optical waveform testing. Not for normal use.
52	GND			

## Top Row Pin Descriptions

Pin Num.	Name	Function	Notes
53	GND		
54	N.C.		
55	N.C.		
56	GND		
57	RX0p	Lane 0 Rx Output	CML Output
58	RX0n	O	
59	GND		
60	RX1p	Lane 1 Rx Output	CML Output
61	RX1n	O	
62	GND		
63	N.C.		
64	N.C.		
65	GND		
66	N.C.		
67	N.C.		
68	GND		
69	RX2p	Lane 2 Rx Output	CML Output
70	RX2n	O	
71	GND		
72	RX3p	Lane 3 Rx Output	CML Output
73	RX3n	O	
74	GND		
75	N.C.		
76	N.C.		
77	GND		

78	(REFCLKn)	Reference Clock	Reference Clock Input
79	(REFCLKp)	I	



80	GND		
81	N.C.		
82	N.C.		
83	GND		
84	TX0p	Lane 0 Tx Input I	CML Input
85	TX0n		
86	GND		
87	TX1p	Lane 1 Tx Input I	CML Input
88	TX1n		
89	GND		
90	N.C.		
91	N.C.		
92	GND		
93	N.C.		
94	N.C.		
95	GND		
96	TX2p	Lane 2 Tx Input I	CML Input
97	TX2n		
98	GND		
99	TX3p	Lane 3 Tx Input I	CML Input
100	TX3n		
101	GND		
102	N.C.		
103	N.C.		
104	GND		

## Mechanical Specifications

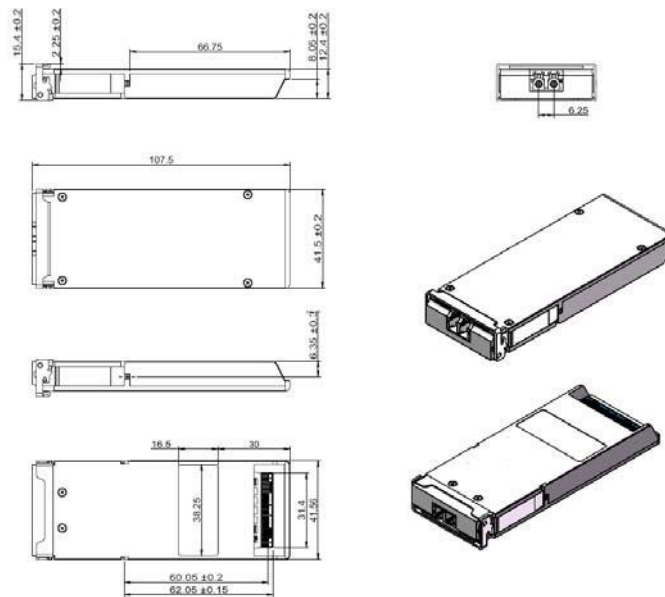

## Revision History

Revision	Initiated	Reviewed	Approved	Revision History	Release Date
V1.a	Andy			Preliminary.	Feb 16, 2018