

DO-GYxxX-10/F-1

SFP28 25Gb/s DWDM 10km Transceiver

PRODUCT FEATURES

- Hot-pluggable SFP28 footprint
- Data rate from 24.33Gbps to 25.78Gbps
- Up to 10km reach with FEC
- 100GHz ITU, C Band DWDM Cooled EML laser
- PIN receiver
- Full Duplex LC connector
- Single 3.3V power supply
- Built-in digital diagnostic functions
- Power dissipation :

Commercial <2W

Industrial <2.3W

- Operating case temperature

Commercial: 0°C to +70°C

Industrial: -40°C to +85°C

APPLICATIONS

- 25G Ethernet
- CPRI & eCPRI

STANDARD

- Compliant to SFF-8431
- Compliant to SFF 8472
- RoHS Compliant.

Product Selection

DO-GYxxX-10/F-1, xx is the channel number

Channel	Wavelength (nm)	Frequency (THZ)	Channel	Wavelength (nm)	Frequency (THZ)
D21	1560.61	192.1	D41	1544.53	194.1
D22	1559.79	192.2	D42	1543.73	194.2
D23	1558.98	192.3	D43	1542.94	194.3
D24	1558.17	192.4	D44	1542.14	194.4
D25	1557.36	192.5	D45	1541.35	194.5
D26	1556.55	192.6	D46	1540.56	194.6
D27	1555.75	192.7	D47	1539.77	194.7
D28	1554.94	192.8	D48	1538.98	194.8
D29	1554.13	192.9	D49	1538.19	194.9
D30	1553.33	193	D50	1537.4	195
D31	1552.52	193.1	D51	1536.61	195.1
D32	1551.72	193.2	D52	1535.82	195.2
D33	1550.92	193.3	D53	1535.04	195.3
D34	1550.12	193.4	D54	1534.25	195.4
D35	1549.32	193.5	D55	1533.47	195.5
D36	1548.51	193.6	D56	1532.68	195.6
D37	1547.72	193.7	D57	1531.9	195.7
D38	1546.92	193.8	D58	1531.12	195.8
D39	1546.12	193.9	D59	1530.33	195.9
D40	1545.32	194	D60	1529.55	196

Absolute Maximum Ratings

Parameter	Symbol	Min.	Typ.	Max.	Unit	Note
Storage Temperature	T_s	-40	-	85	°C	
Relative Humidity	R_H	0	-	85	%	
Power Supply Voltage	V_{CC}	-0.3	-	4.00	V	

Recommended Operating Conditions

Parameter	Symbol	Min.	Typ.	Max.	Unit	Note
Case Operating Temperature	T_{case}	0	-	70	°C	Commercial
		-40	-	85	°C	Industrial
Supply Voltage	V_{cc3}	3.13		3.47	V	
Data Rate	BR	24.33		25.78	Gbps	

Optical Characteristics

Parameter	Symbol	Min.	Typ.	Max.	Unit	Note
Transmitter						
Wavelength	λ	1529.55		1560.61		
Center Wavelength Spacing		100			GHz	
Wavelength Tolerance		-0.08		0.08	nm	
Average Launched Power	P_O	-1		5	dBm	
AExtinction Ratio	ER	6		-	dB	
Average Launched Power(Laser Off)	P_{off}	-	-	-30	dBm	
Side-Mode Suppression Ratio	SMSR	30	-	-	dB	
Relative Intensity Noise	RIN ₂₀ OMA			-130	dB/Hz	
Receiver						
Center Wavelength	λ_{IN}	1260	-	1620	nm	
Receiver Overload	$P_{overload}$	2			dBm	
Receiver Sensitivity @5E-5 BOL	$P_{sen\ BOL}$			-15	dBm	Note1
Receiver Sensitivity @5E-5 EOL	$P_{sen\ EOL}$			-14.5	dBm	Note1
Receiver Sensitivity @5E-5 EOL after 10km fiber transmission	$P_{sen1\ EOL}$			-8.0	dBm	Note1
Los Of Signal Assert	P_A	-30	-	-	dBm	
Los Of Signal De-assert	P_D	-	-	-16	dBm	
LOS -Hysteresis	P_{Hys}	0.5		6	dB	

Note1: Measured at 5E-5, ER>4dB, PRBS 2³¹-1

Electrical Interface Characteristics

Parameter	Symbol	Min.	Typ.	Max.	Unit	Note
Transmitter						
Data Input Swing Differential	V_{IN}	190		1000	mV	
Differential line input Impedance	R_{IN}	80	100	120	Ohm	
Transmitter Fault Output-High	V_{FaultH}	2	-	$V_{CC}+0.3$	V	
Transmitter Fault Output-Low	V_{FaultL}	V_{EE}	-	$V_{EE}+0.8$	V	
Transmitter Disable Voltage-High	V_{DisH}	2	-	$V_{CC}+0.3$	V	
Transmitter Disable Voltage- low	V_{DisL}	V_{EE}	-	$V_{EE}+0.8$	V	
Receiver						
Differential line Output Impedance	R_{OUT}	80	100	120	Ohm	
Differential Data Output Voltage	V_{DR}	350	-	850	mVp-p	
LOS Output Voltage-High	V_{LOSH}	2	-	$V_{CC}+0.3$	V	
LOS Output Voltage-Low	V_{LOSL}	V_{EE}	-	$V_{EE}+0.8$	V	
Others、						
Cold-Start time	$T_{start-cooled}$			35	s	

Transmitter Input Equalization

Code (Note1) In A2h, Byte 114 bit4-7	Transmitter Input Equalization	
	Nominal	Units
11xx	Reserved	
1011	Reserved	
1010	10	dB
1001	9	dB
1000	8	dB
0111	7	dB
0110	6	dB
0101	5	dB
0100	4	dB
0011	3	dB
0010	2	dB
0001	1	dB
0000	0	No EQ

Note:

1. Only A2h, Byte 114 bit4-7 is assigned for Tx equalization control.

Receiver Output Emphasis

Code (Note1) In A2h, Byte 115 bit4-7	Receiver Output Emphasis At nominal Output Amplitude	
	Nominal	Units
1xxx	Vendor Specific	
0111	7	dB
0110	6	dB
0101	5	dB
0100	4	dB
0011	3	dB
0010	2	dB
0001	1	dB
0000	0	No Emphasis

Note:

1. Only A2h, Byte 115 bit4-7 is assigned for Rx emphasis control.

Pin Description

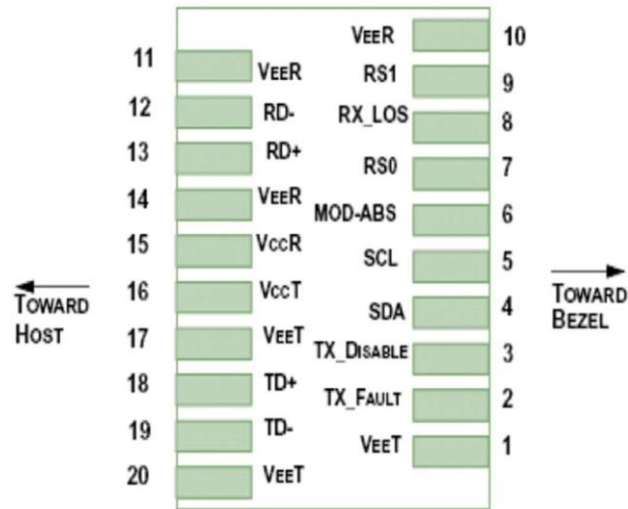

Diagram of Host Board Connector Block Pin Numbers and Name

Pin	Symbol	Name/Description	NOTE
1	V_{EET}	Transmitter Ground (Common with Receiver Ground)	1
2	T_{FAULT}	Transmitter Fault.	2
3	T_{DIS}	Transmitter Disable. Laser output disabled on High or open.	3
4	SDA	2-wire Serial Interface Data Line	4
5	SCL	2-wire Serial Interface Clock Line	4
6	MOD_ABS	Module Absent. Grounded within the module	4
7	RS0	Rate Select 0, internal pull down	5
8	LOS	Loss of Signal indication. Logic 0 indicates normal operation.	6
9	RS1	Rate Select 1, internal pull down	1
10	V_{EER}	Receiver Ground (Common with Transmitter Ground)	1
11	V_{EER}	Receiver Ground (Common with Transmitter Ground)	1
12	RD-	Receiver Inverted DATA out. AC Coupled	
13	RD+	Receiver Non-inverted DATA out. AC Coupled	
14	V_{EER}	Receiver Ground (Common with Transmitter Ground)	1
15	V_{CCR}	Receiver Power Supply	
16	V_{CCT}	Transmitter Power Supply	
17	V_{EET}	Transmitter Ground (Common with Receiver Ground)	1
18	TD+	Transmitter Non-Inverted DATA in. AC Coupled.	
19	TD-	Transmitter Inverted DATA in. AC Coupled.	
20	V_{EET}	Transmitter Ground (Common with Receiver Ground)	1

1. Circuit ground is internally isolated from chassis ground.

2. T_{FAULT} is an open collector/drain output, which should be pulled up with a 4.7k – 10k Ohms resistor on the host board if intended for use. Pull up voltage should be between 2.0V to $V_{cc} + 0.3V$. A high output indicates a transmitter fault caused by either the TX bias current or the TX output power exceeding the preset alarm thresholds. A low output indicates normal operation. In the low state, the output is pulled to $<0.8V$.
3. Laser output disabled on $T_{DIS}>2.0V$ or open, enabled on $T_{DIS}<0.8V$.
4. Should be pulled up with 4.7k Ω - 10k Ω host board to a voltage between 2.0V and 3.6V. MOD_ABS pulls line low to indicate module is plugged in.
5. Internally pulled down per SFF-8431 Rev 4.1.
6. LOS is open collector output. It should be pulled up with 4.7k Ω – 10k Ω on host board to a voltage between 2.0V and 3.6V. Logic 0 indicates normal operation; logic 1 indicates loss of signal.

Block Diagram of Transceiver

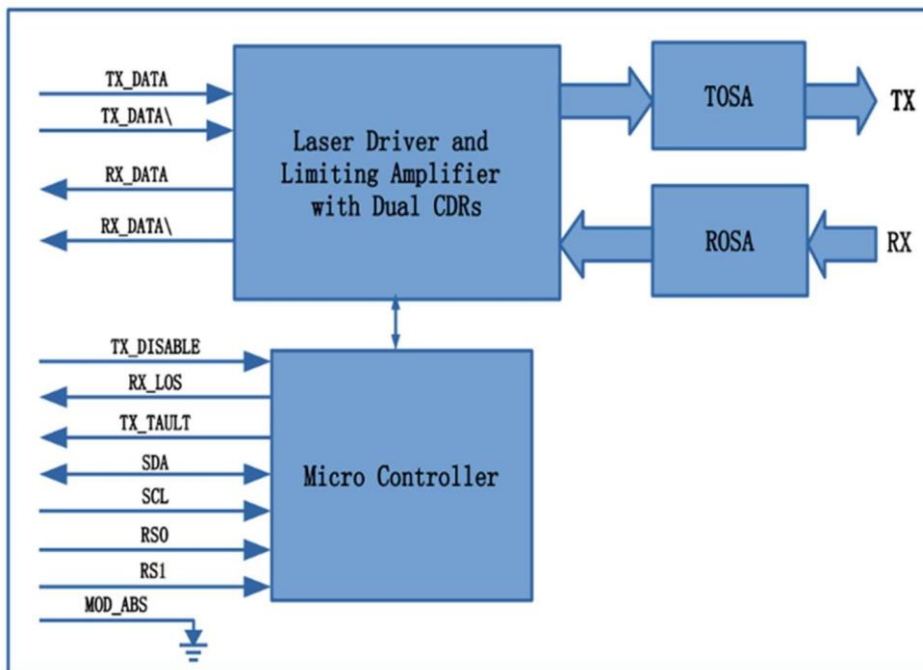

Recommended Interface Circuit

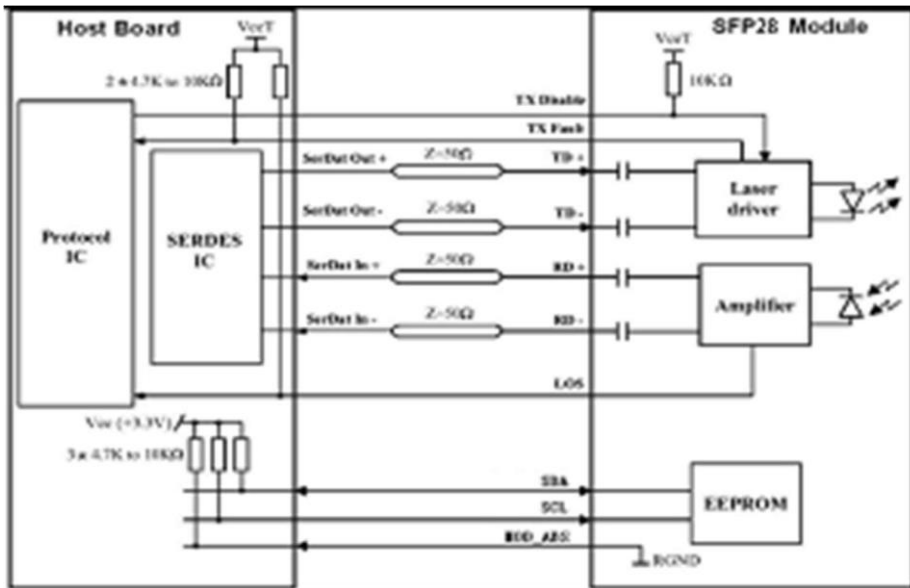

Mechanical Specifications

