

800G-2xFR4 2km OSFP

Features:

- Compliant with IEEE 802.3cu-2021:
- - 2x400GBASE-FR4 optical interface
- Compliant with IEEE P802.3ck D3.0
- - 2x400GAUI-4 C2M electrical interface
- Compliant with OSFP MSA HW Rev 4.1
- Type 2 housing with dual LC connector
- Compliant with CMIS Rev 5.0
- Case operating temperature 0°C to 70°C
- Two wire serial Interface with digital diagnostic monitoring
- Complies with EU Directive 2011/65/EU (RoHS compliant)
- Class 1 Laser

Module Characteristics

Table 1 – Absolute Maximum Ratings

Parameter	Symbol	Min.	Max.	Unit	Notes
Storage Temperature	T_S	-40	85	°C	
Supply Voltage	V_{CC}	-0.5	3.6	V	
Relative Humidity (non-condensing)	RH	5	95	%	
Data Input Voltage Differential	$ V_{DIP}-V_{DIN} $	-	1	V	
Control Input Voltage	V_I	-0.3	$V_{CC}+0.5$	V	
Control Output Current	I_O	-20	20	mA	

Table 2 – Recommended Operating Conditions

Parameter	Symbol	Min.	Typical	Max.	Unit	Notes
Operating Case Temperature	T_{OPR}	0	-	70	°C	1
Power Supply Voltage	V_{CC}	3.135	3.3	3.465	V	
Instantaneous peak current at hot plug	I_{CC_IP}	-	-	TBD	mA	
Sustained peak current at hot plug	I_{CC_SP}	-	-	TBD	mA	
Maximum Power Dissipation	P_D	-	-	TBD	W	
Maximum Power Dissipation, Low Power Mode	P_{DLP}	-	-	2	W	
Signalling Speed per Lane	DRL	-	53.125	-	GBd	
Control Input Voltage High	V_{IH}	$V_{CC}*0.7$	-	$V_{CC}+0.3$	V	
Control Input Voltage Low	V_{IL}	-0.3	-	$V_{CC}*0.3$	V	
Two Wire Serial Interface Clock Rate	-	-	-	400	kHz	
Power Supply Noise 1 kHz - 1 MHz (p-p)	-	-	-	66	mVpp	

Parameter	Symbol	Min.	Typical	Max.	Unit	Notes
Operating Distance	-	2	-	2000	m	

Functional Characteristics (Optical)

The following tables list the performance specifications for the various functional blocks of the integrated optical transceiver module.

Table 3 – Transmitter Optical Specifications

Parameter	Symbol	Min.	Typical	Max.	Unit	Notes
Wavelength L0, L4	$\lambda_{C0}, \lambda_{C4}$	1264.5	1271	1277.5	nm	
Wavelength L1, L5	$\lambda_{C1}, \lambda_{C5}$	1284.5	1291	1297.5	nm	
Wavelength L2, L6	$\lambda_{C2}, \lambda_{C6}$	1304.5	1311	1317.5	nm	
Wavelength L3, L7	$\lambda_{C3}, \lambda_{C7}$	1324.5	1331	1337.5	nm	
Side Mode Suppression Ratio	SMSR	30	-	-	dB	
Total average launch power	AOP_T	-	-	10.4	dBm	
Average Launch Power, each lane	AOP_L	-3.2	-	4.4	dBm	1
Outer Optical Modulation Amplitude (OMA _{outer}), each Lane for TDECQ <1.4 dB for 1.4 dB ≤ TDECQ ≤ 3.4 dB	T_{OMA}	-0.2 -1.6 + TDECQ	-	3.7	dBm	
Difference in launch power between any two lanes (OMA _{outer})	AOP_d	-	-	3.9	dB	
Transmitter and Dispersion Eye Closure for PAM4 (TDECQ), each lane	TDECQ	-	-	3.4	dB	
Transmitter eye closure for PAM4 (TECQ), each lane	TECQ	-	-	3.4	dB	
TDECQ – TECQ	-	-	-	2.5	dB	
Over/under-shoot	-	-	-	22	%	
Transmitter power excursion	-	-	-	1.8	dBm	
Average Launch Power of OFF Transmitter, each lane	T_{OFF}	-	-	-16	dBm	
Extinction Ratio	ER	3.5	-	-	dB	
Transmitter transition time (max)	T_r	-	-	17	ps	
RIN _{17,1} OMA (max)	RIN	-	-	-136	dB/Hz	
Optical Return Loss Tolerance	ORL	-	-	17.1	dB	
Transmitter Reflectance	T_R	-	-	-26	dB	2

Note 1: Average launch power, each lane (min) is informative and not the principal indicator of signal strength

Note 2: Transmitter reflectance is defined looking into the transmitter

Table 4 – Receiver Optical Specifications

Parameter	Symbol	Min.	Typical	Max.	Unit	Notes
Wavelength L0, L4	$\lambda_{C0}, \lambda_{C4}$	1264.5	1271	1277.5	nm	
Wavelength L1, L5	$\lambda_{C1}, \lambda_{C5}$	1284.5	1291	1297.5	nm	
Wavelength L2, L6	$\lambda_{C2}, \lambda_{C6}$	1304.5	1311	1317.5	nm	
Wavelength L3, L7	$\lambda_{C3}, \lambda_{C7}$	1324.5	1331	1337.5	nm	
Damage Threshold, each Lane	AOP _D	5.4	-	-	dBm	
Average Receive Power, each Lane	AOP _R	-7.2	-	4.4	dBm	
Receive Power (OMA _{outer}), each Lane	OMA _R	-	-	3.7	dBm	
Difference in receive power between any two lanes (OMA _{outer}) (max)	AOP _G	-	-	4.1	dB	
Receiver Reflectance	RR	-	-	-26	dB	
Receiver sensitivity (OMA _{outer}), each lane for TECQ < 1.4 dB for 1.4 dB ≤ TECQ ≤ 3.4 dB	S _{OMA}	-	-	-4.6 - 6 + TECQ	dBm	
Stressed Receiver Sensitivity (OMA _{outer}), each Lane	SRS	-	-	-2.6	dBm	1
Conditions of stressed receiver sensitivity test						
Stressed eye closure for PAM4 (SECQ), lane under test	-	-	3.4	-	dB	
OMA _{outer} of each aggressor lane	-	-	1.4	-	dBm	

Note 1: Measured with conformance test signal at TP3 for the BER = 2.4x10⁻⁴

Functional Characteristics (Electrical)

Table 5 – Electrical Specification High Speed Signal (compliant with IEEE802.3ck C2M)

Receiver (Module Output, TP4)						
Parameter	Symbol	Min.	Typical	Max.	Unit	Notes
AC common-mode output Voltage (RMS)	-	-	-	25	mV	
Differential peak-to-peak output voltage Short mode Long mode	-	-	-	600 845	mV	
Eye height	EH	15	-	-	mV	
Vertical eye closure	VEC	-	-	12	dB	
Common-mode to differential-mode return loss	RLDc	802.3ck 120G-1			dB	
Effective return loss	ERL	8.5	-	-	dB	
Differential termination mismatch	-	-	-	10	%	
Transition time	-	8.5	-	-	ps	
DC common-mode voltage tolerance	-	-0.35	-	2.85	V	
Transmitter (Module Input, TP1)						
Parameter	Symbol	Min.	Typical	Max.	Unit	Notes
Differential pk-pk input Voltage tolerance (TP1a)	-	750	-	-	mV	
AC common-mode RMS voltage tolerance (TP1a)	-	25	-	-	mV	
Differential-mode to common-mode return loss	RLcd	802.3ck 120G-2			dB	
Effective return loss	ERL	8.5	-	-	dB	
Differential termination mismatch	-	-	-	10	%	
Single-ended voltage tolerance range	-	-0.4	-	3.3	V	
DC common-mode voltage tolerance	-	-0.35	-	2.85	V	

Table 6 – Electrical Specification Low Speed Control and Sense Signals (compliant with QSFP-DD HW Rev 6.01 Table 14)

Parameter	Symbol	Min.	Max.	Unit	Condition
Module output SCL and SDA	V_{OL}	0	0.4	V	
Module Input SCL and SDA	V_{IL}	-0.3	$V_{CC} \cdot 0.3$	V	
	V_{IH}	$V_{CC} \cdot 0.7$	$V_{CC} + 0.5$	V	
InitMode, ResetL and ModSelL	V_{IL}	-0.3	0.8	V	
	V_{IH}	2	$V_{CC} + 0.3$	V	
IntL	V_{OL}	0	0.4	V	
	V_{OH}	$V_{CC} - 0.5$	$V_{CC} + 0.3$	V	

Pin Definitions

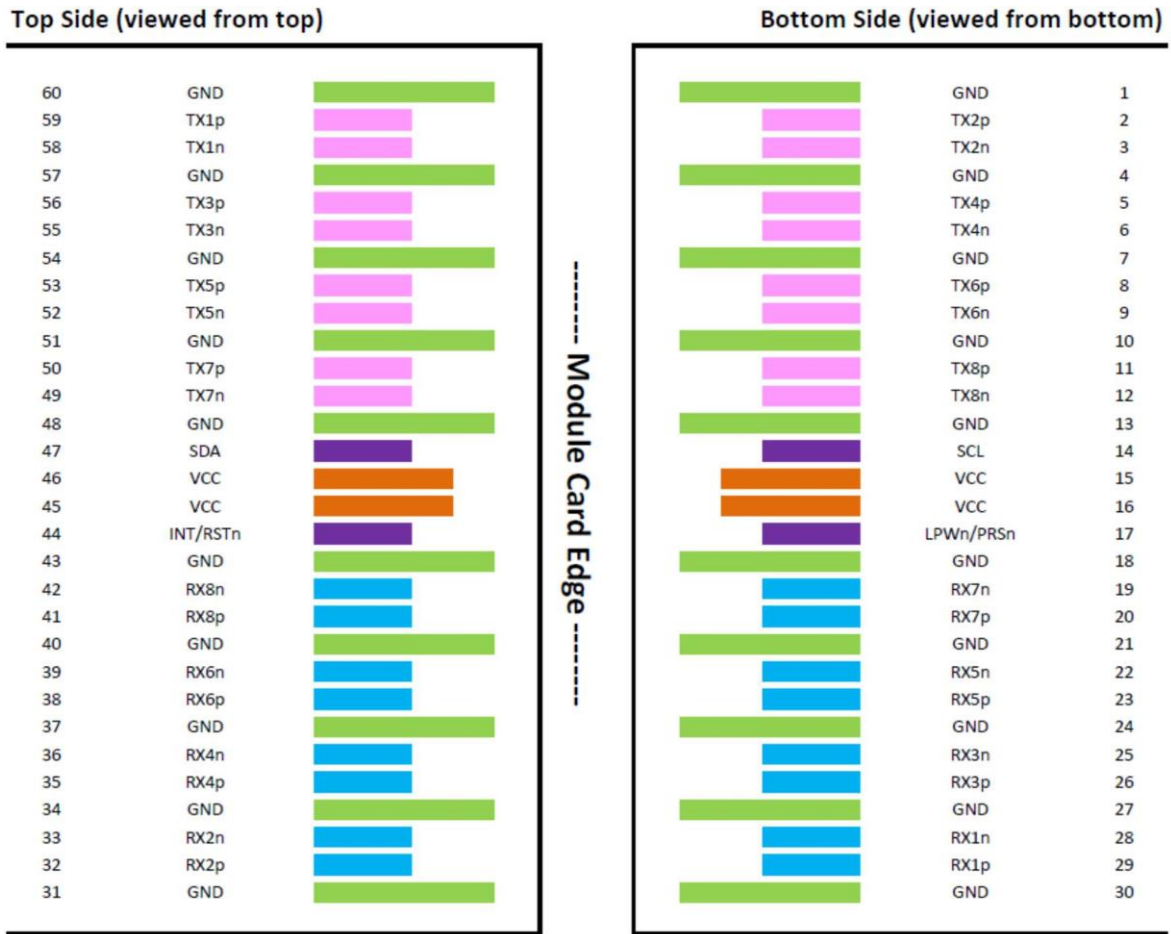

Figure 1 – Pinout definitions of OSFP module inputs/outputs

Table 7 – Module Pin Definitions

Pin #	Symbol	Description	Logic	Pin #	Symbol	Description	Logic
1	GND	Ground		31	GND	Ground	
2	TX2p	Transmitter Data Non-Inverted	CML-I	32	RX2p	Receiver Data Non-Inverted	CML-O
3	TX2n	Transmitter Data Inverted	CML-I	33	RX2n	Receiver Data Inverted	CML-O
4	GND	Ground		34	GND	Ground	
5	TX4p	Transmitter Data Non-Inverted	CML-I	35	RX4p	Receiver Data Non-Inverted	CML-O
6	TX4n	Transmitter Data Inverted	CML-I	36	RX4n	Receiver Data Inverted	CML-O
7	GND	Ground		37	GND	Ground	
8	TX6p	Transmitter Data Non-Inverted	CML-I	38	RX6p	Receiver Data Non-Inverted	CML-O
9	TX6n	Transmitter Data Inverted	CML-I	39	RX6n	Receiver Data Inverted	CML-O
10	GND	Ground		40	GND	Ground	
11	TX8p	Transmitter Data Non-Inverted	CML-I	41	RX8p	Receiver Data Non-Inverted	CML-O
12	TX8n	Transmitter Data Inverted	CML-I	42	RX8n	Receiver Data Inverted	CML-O
13	GND	Ground		43	GND	Ground	
14	SCL	2-wire Serial interface clock	LVC MOS-I/O	44	INT/RSTn	Module Interrupt / Module Reset	Multi-Level
15	VCC	+3.3V Power		45	VCC	+3.3V Power	
16	VCC	+3.3V Power		46	VCC	+3.3V Power	
17	LPWn/PRSn	Low-Power Mode / Module Present	Multi-Level	47	SDA	2-wire Serial interface data	LVC MOS-I/O
18	GND	Ground		48	GND	Ground	
19	RX7n	Receiver Data Inverted	CML-O	49	TX7n	Transmitter Data Inverted	CML-I
20	RX7p	Receiver Data Non-Inverted	CML-O	50	TX7p	Transmitter Data Non-Inverted	CML-I
21	GND	Ground		51	GND	Ground	
22	RX5n	Receiver Data Inverted	CML-O	52	TX5n	Transmitter Data Inverted	CML-I
23	RX5p	Receiver Data Non-Inverted	CML-O	53	TX5p	Transmitter Data Non-Inverted	CML-I
24	GND	Ground		54	GND	Ground	
25	RX3n	Receiver Data Inverted	CML-O	55	TX3n	Transmitter Data Inverted	CML-I
26	RX3p	Receiver Data Non-Inverted	CML-O	56	TX3p	Transmitter Data Non-Inverted	CML-I
27	GND	Ground		57	GND	Ground	
28	RX1n	Receiver Data Inverted	CML-O	58	TX1n	Transmitter Data Inverted	CML-I
29	RX1p	Receiver Data Non-Inverted	CML-O	59	TX1p	Transmitter Data Non-Inverted	CML-I
30	GND	Ground		60	GND	Ground	

Recommended OSFP Host Board Schematic

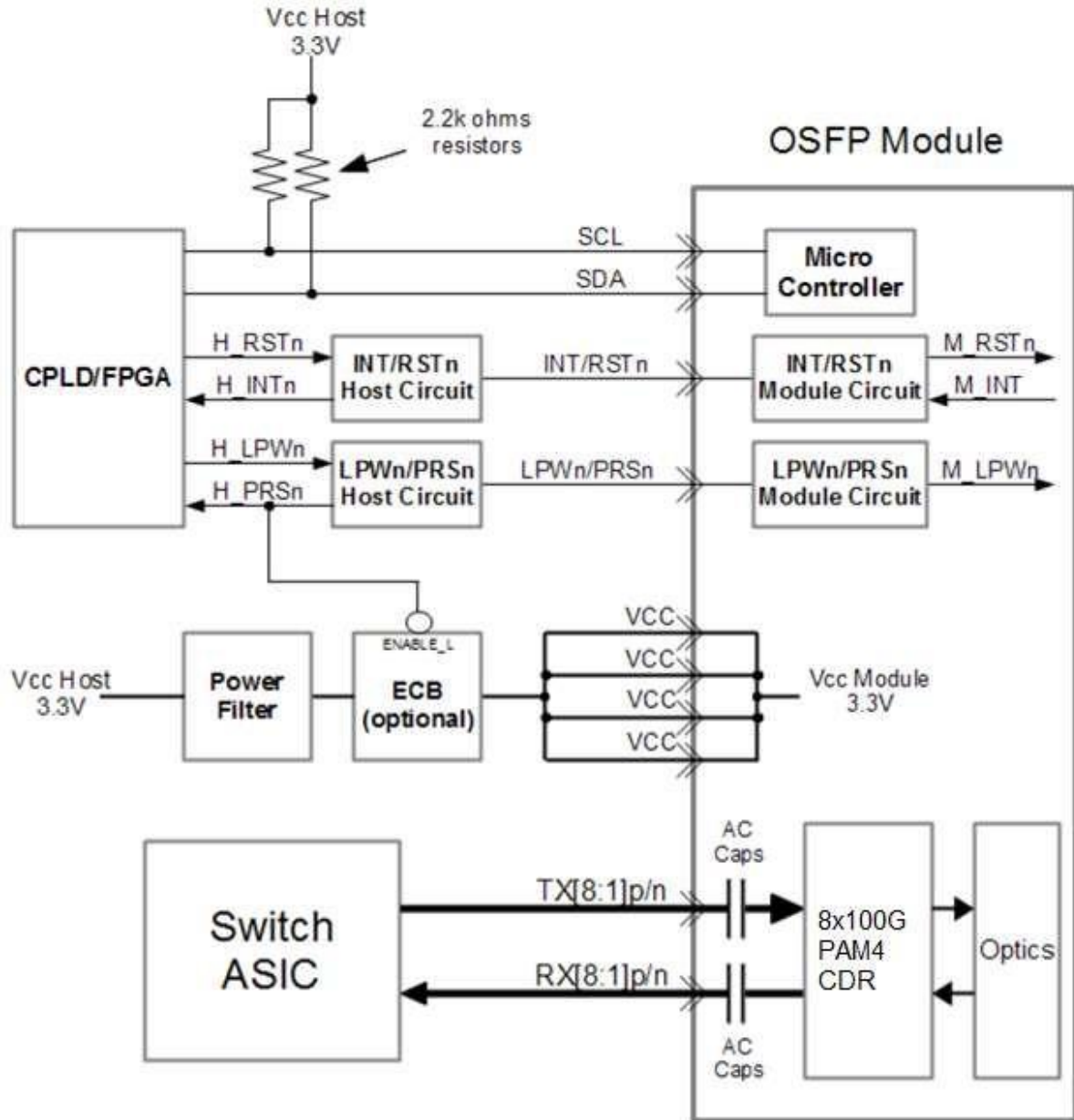
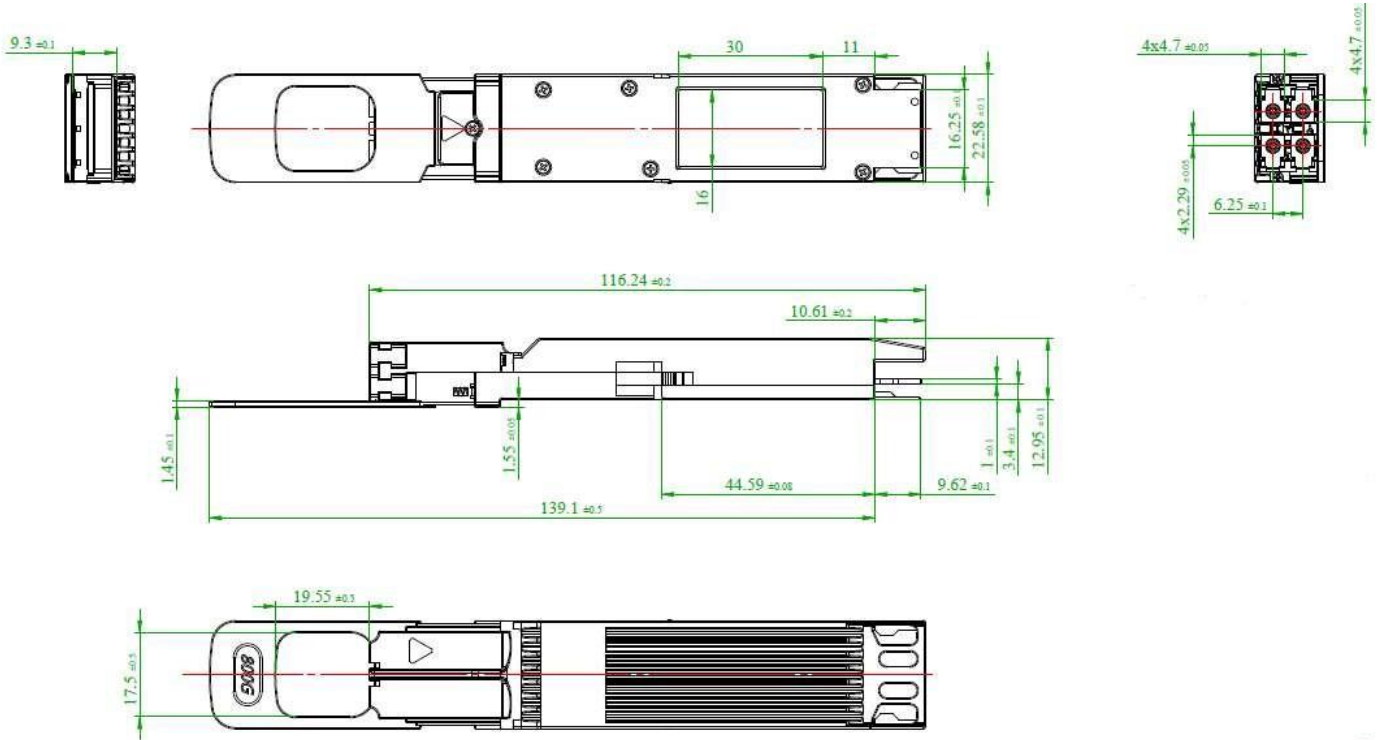

Figure 2 – Recommended OSFP Host Board Schematic

Table 8 – Digital Diagnostics

Parameter	Range	Accuracy	Unit	Calibration
Temperature	0 to 70	±3	°C	Internal
Voltage	0 to V _{CC}	0.1	V	Internal
Tx Bias Current (Each Lane)	0 to 100	10%	mA	Internal
Tx Output Power (Each Lane)	-3.2 to +4.4	±3	dB	Internal
Rx Receive Power (Each Lane)	-7.2 to +4.4	±3	dB	Internal

Mechanical Diagram



Ordering Information

Table 9 - Ordering Information

Part No.	Application	Data Rate	Laser	Fiber Type
DO-800G-O-FR	2x400GBASE-FR4 8x100GBASE-FR1	850Gb/s	EML	Single Mode Fiber



Warnings

Handling Precautions: This device is susceptible to damage as a result of electrostatic discharge (ESD). A static free environment is highly recommended. Follow guidelines according to proper ESD procedures.

Laser Safety: Radiation emitted by laser devices can be dangerous to human eyes. Avoid eye exposure to direct or indirect radiation.